

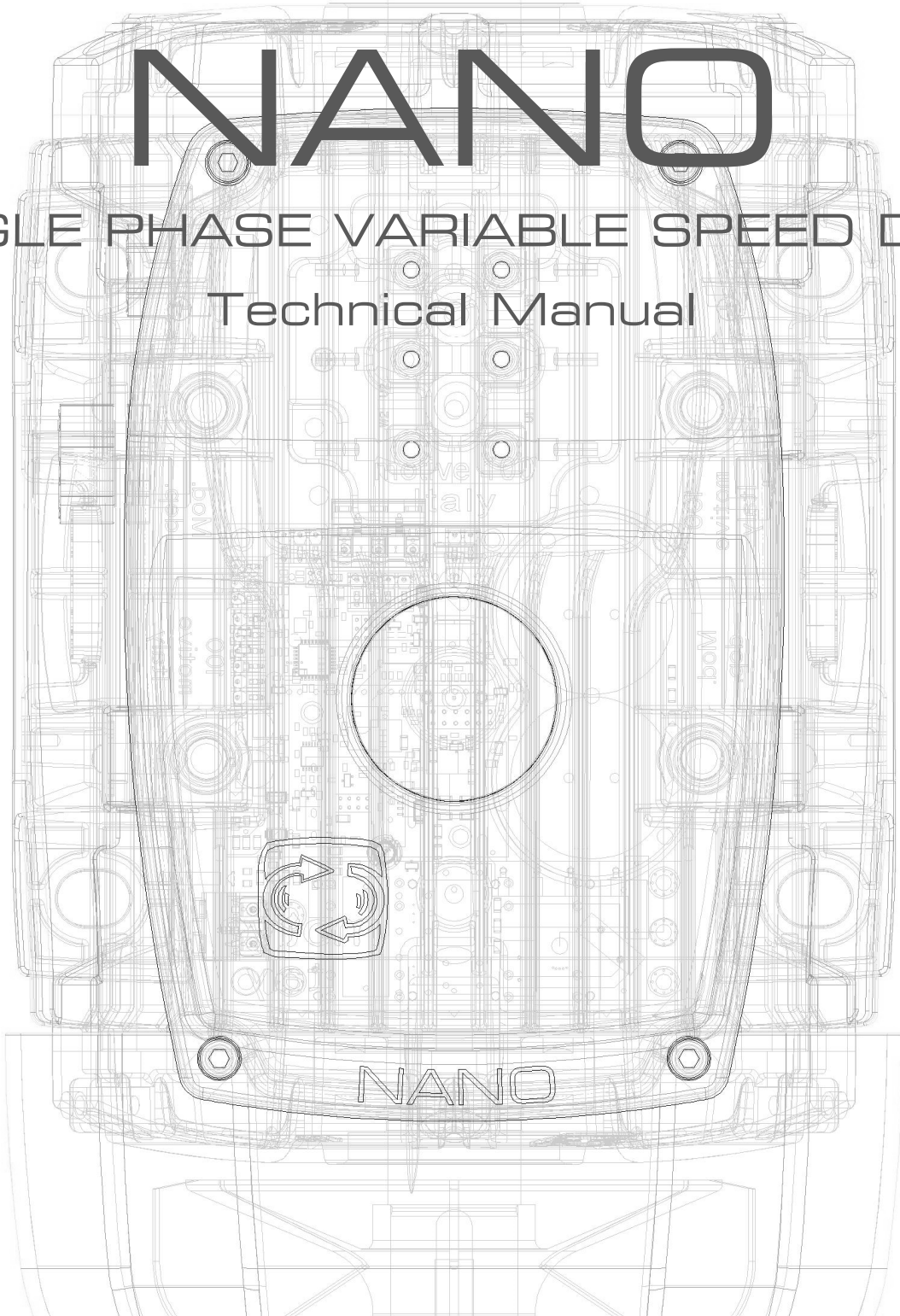

NANO

SINGLE PHASE VARIABLE SPEED DRIVE

Technical Manual



CONTENTS:

1. INTRODUCTION
2. WORKING CONDITIONS
3. MOTORS CONNECTABLE
4. MECHANICAL ASSEMBLY
 - 4a. Dimensions
 - 4b. Motor mounting
 - 4b.1 Forced Ventilation
 - 4b.2 Brake motors manual release lever
 - 4c. Wall mounting (optional code WALL-NANO)
5. ELECTRICAL ASSEMBLY
 - 5a. Warnings
 - 5b. NANO electrical connection
 - 5b.1 Dimensions of protection and safety devices
 - 5b.2 Motor connection
 - 5b.3 Diagrams
 - 5c. General electrical drawing
 - 5d. External devices connection
 - 5d.1 Examples
 - 5d.2 Bluetooth module mounting (optional code BLUE)
 - 5d.3 Power switch mounting (optional code ITEM1X12A)
 - 5d.4 Potentiometer mounting (optional code NANPOT)
6. FUNCTIONS
 - 6a. Main characteristics
 - 6b. Alarms
 - 6c. Modbus
7. MOTIVE MOTOR MANAGER
 - 7a. Download and Installation
 - 7b. USB-RS485 Converter connection settings
 - 7c. Main functions
 - 7d. Reading and writing parameters
 - NANO Modbus Variables table chart
8. WARNINGS AND RISKS
9. DECLARATION OF CONFORMITY

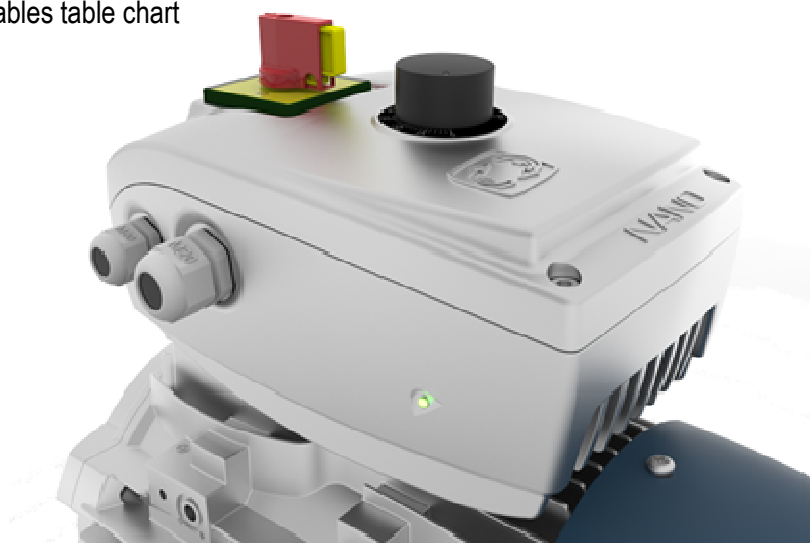

1. INTRODUCTION

NANO is a variable speed drive for single phase grid, three phase motors
NANO is easy to use, IP65,

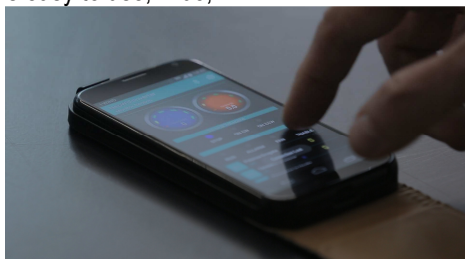

remotable wireless bluetooth by smartphone or tablet

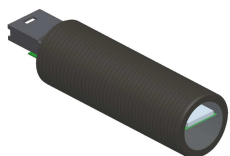

thanks to its specific "BLUE" transmitter and



NANO APP for Android and IOS.

It can also be programmed and controlled by a free PC Software via USB port, by a PLC and by commands and sensors.



A potentiometer and/or a switch can be incorporated in its case.

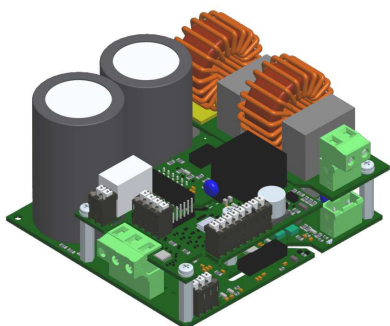

The electronic parts are modular, for a better adaptation to the specific needs of each application

NANO is also offered in the versions "NANO-COMP", "NANO-VENT" and "NANO-OLEO", with a SW specifically modified for the automatic speed+power adaptation to the required pressure and variable flow rate of air compressors, fans, pumps, hydraulic power packs

With NANO, the manufacturers can offer finished "plugin" products, without delegating risky and costly installations to their customers.

2. WORKING CONDITIONS



Physical dimension	Symbol	U.O.M.	NANO-0,75kW (OLD)	NANO-1,1kW (NEW)	NANO-2,2kW
Inverter protection degree*	IP		IP65*		
Inverter input voltage	V_{1n}	V	1x 110(-10%)=240(+10%)		
Inverter input frequency	f_{1n}	Hz	50/60 ($\pm 5\%$)		
Maximum output voltage of the inverter	V_2	V	$0,95 \cdot V_{1n}$		
Inverter output frequency	f_2	Hz	200% f_{1n} (f_2 0÷100Hz with f_{1n} 50Hz)		
Rated input inverter current	I_{1n}	A	5	5	10
Rated output inverter current (to the motor)	I_{2n}	A	4	4	9
Maximum continuous output inverter current	I_2	A	$I_{2n} + 5\%$		
Maximum Starting torque / Rated torque ratio	Cs/Cn	Nm	150%		
Maximum Starting current (kept for 3 seconds)	I_{2max}	A	200% I_2		
Storage temperature	T_{stock}	°C	-20 ÷ +70		
Environmental operating temperature (at I_{2n} max)	T_{amb}	°C	-20 ÷ +40		
Maximum relative humidity		% (40°C)	5 ... 85 without condensation		
Power losses (% motor speed ; % load torque)	(0 ; 25)	%	8.9 (IE2)	8.9 (IE2)	4.5 (IE2)
	(0 ; 50)	%	9.0 (IE2)	9.0 (IE2)	4.8 (IE2)
	(0 ; 100)	%	9.5 (IE2)	9.5 (IE2)	5.5 (IE2)
	(50 ; 25)	%	9.1 (IE2)	9.1 (IE2)	4.6 (IE2)
	(50 ; 50)	%	9.2 (IE2)	9.2 (IE2)	5.0 (IE2)
	(50 ; 100)	%	10.0 (IE2)	10.0 (IE2)	6.1 (IE2)
	(90 ; 50)	%	9.6 (IE2)	9.6 (IE2)	5.4 (IE2)
(90 ; 100)	%	11.0 (IE2)	11.0 (IE2)	7.2 (IE2)	
Stand-by losses		W	4	4	4

Other characteristics	NANO-0,75kW (OLD)	NANO-1,1kW (NEW)	NANO-2,2kW
Motor control	V / F		
EMC class B for DOMESTIC, COMMERCIAL AND LIGHT INDUSTRIAL ENVIRONMENT	With optional code NANFILT or with external EMC filter		
EMC class B for INDUSTRIAL ENVIRONMENT			
Analog/Digital I/O Module	Optional code NANEXPS	included	
Power Switch IP65	Optional code INTEM1X12A		
Potentiometer with Knob and Unit Scale IP65	Optional code NANPOT		
Bluetooth module for smartphone and tablet control	Optional code BLUE		
Communication Protocol	MODBUS RS485		

For different environmental conditions, please contact our Support Service.

*IP65 degree refers to the inverter case and to the optional components on the cover (Power Switch and Potentiometer).

3. MOTORS CONNECTABLE

Table RP: Power range of motors that can be connected (at 3PH 230Vac)

KW motor	0,13	0,18	0,25	0,37	0,55	0,75	1,1	1,5	1,9	2,2
NANO-1,1 kW										
NANO-2,2kW										

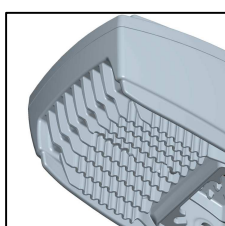

The power that can be applied is dependent not only on the electronic characteristics of NANO, but also on the dissipative capacity of its case. It is therefore not allowable to use the electronic board in different housings by removing the electronic board and mounting it in another case. This transfer would also compromise its electrical insulation and safety with resulting inapplicability of the warranty.

Table RD: Size range of IEC motors that can be connected

IEC Motor	63	71	80	90S	90L	100L	112M	132S
NANO1,1kW	A	A	A	A	A	NA		
NANO-2,2kW			A	A	A	NA	NK	NK

A: Required to keep the standard mechanical adapter, as shown in chapter 4.

NA: The standard adapter supplied with NANO shall not be used.

NK: After removing the knockouts, as shown in chapter 4.

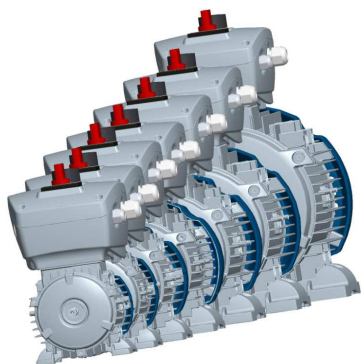

Why connect motors size 90 and 100 to a NANO-0,75kW or motors size 132S to a NANO-2,2kW? Because motors with more than 4 poles can be a greater size (for example 112M-6 2,2kW, 132S-8 2,2kW).

It is important that the motor is suitable to be powered by Variable Speed Drive VSD. A fundamental requirement is that it has reinforced insulation between the phase windings. Others, are the limited current absorption and low temperature rise, since the current is the limit of an inverter and the motor temperature will heat the inverter. The Motive Delphi series motors, as a standard feature, can be powered by an inverter and are designed to fit with motive VSD

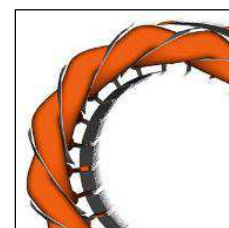

4. MECHANICAL ASSEMBLY

4a. Dimensions

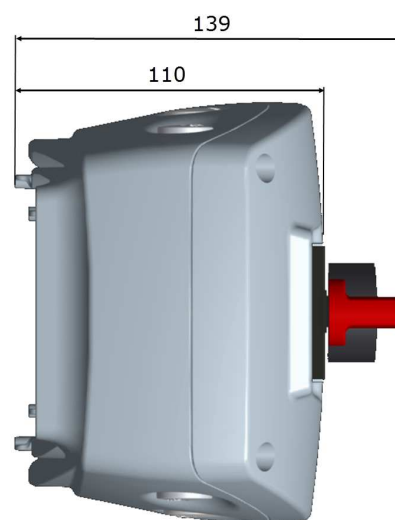
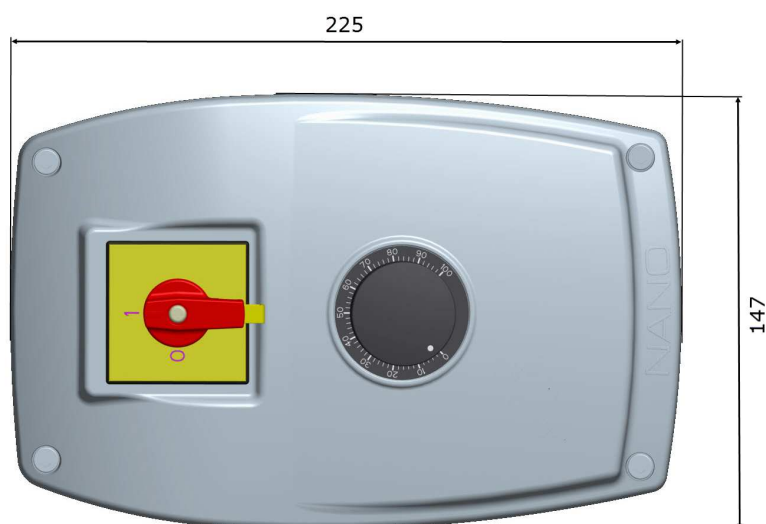

NANO + Motor dimensions

IEC Motor	AD1	AD2	L
63	160	188	256
71	166	195	272
80	181	210	278
90S	190	215	293
90L	190	215	293
100L	200	227	300
112	211	240	304
132S	230	258	335

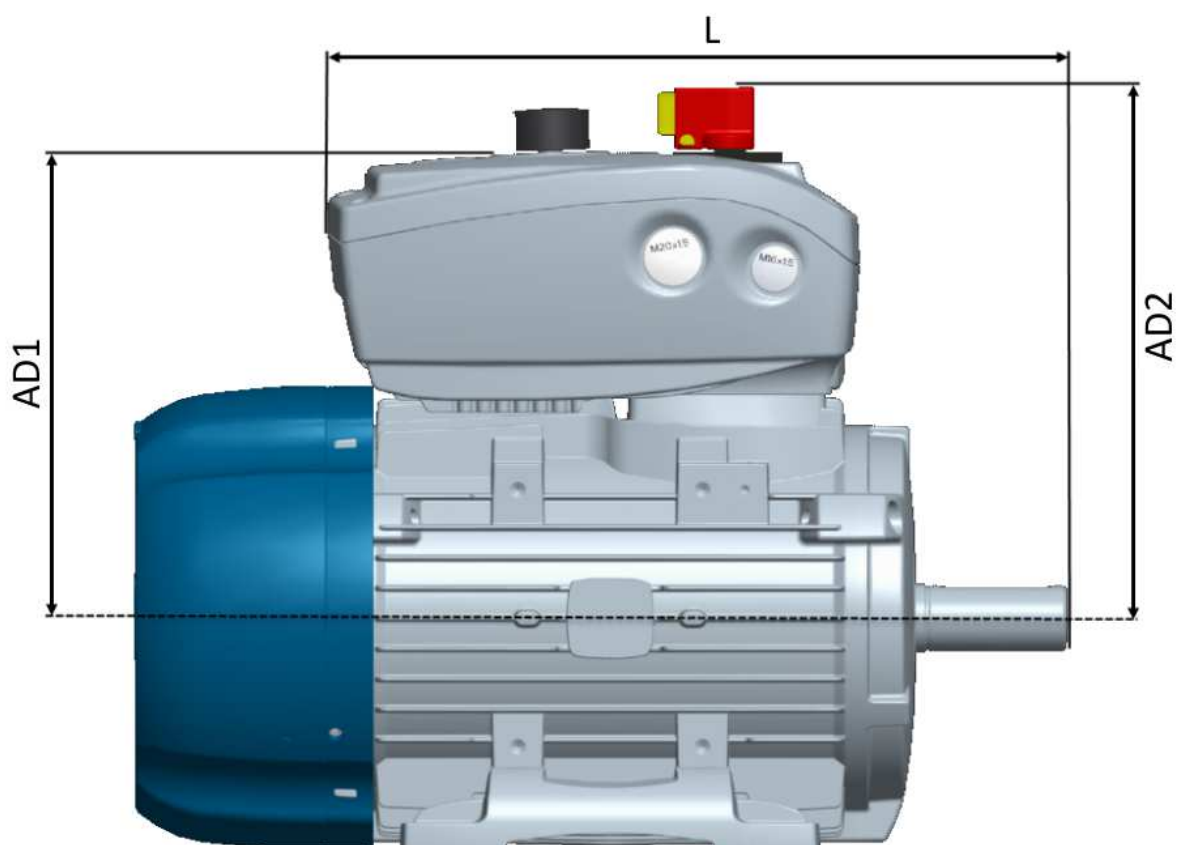

4b. Motor mounting

The mechanical fastening with slots (Fig.5), allows the NANO case to be fixed onto a wide range of Delphi series Motive motors from size 63 to size 132 (Table RD)

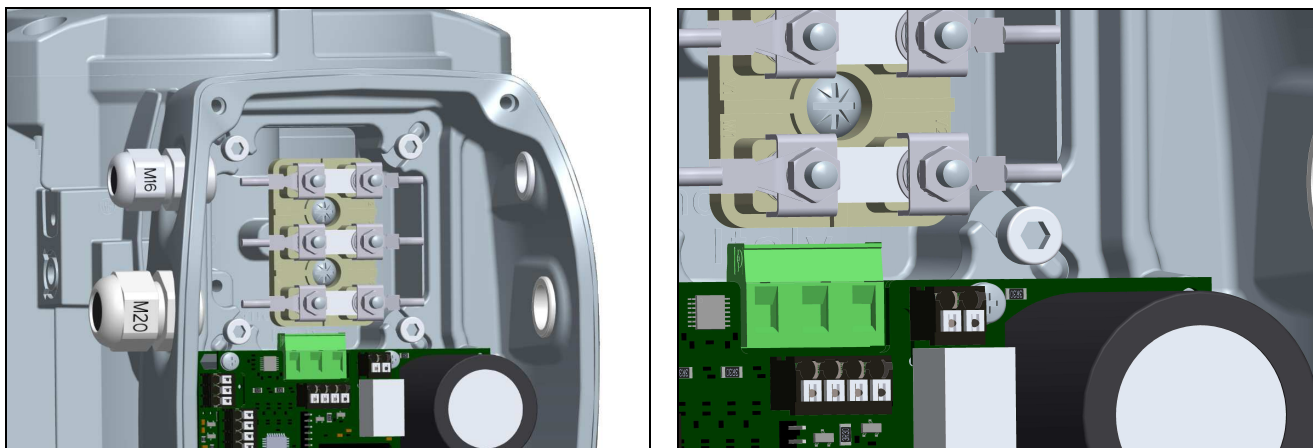

The knockouts allow NANO to broaden its field of use to engines with greater sizes (Table RD), as shown below:



Knockout removing procedure:

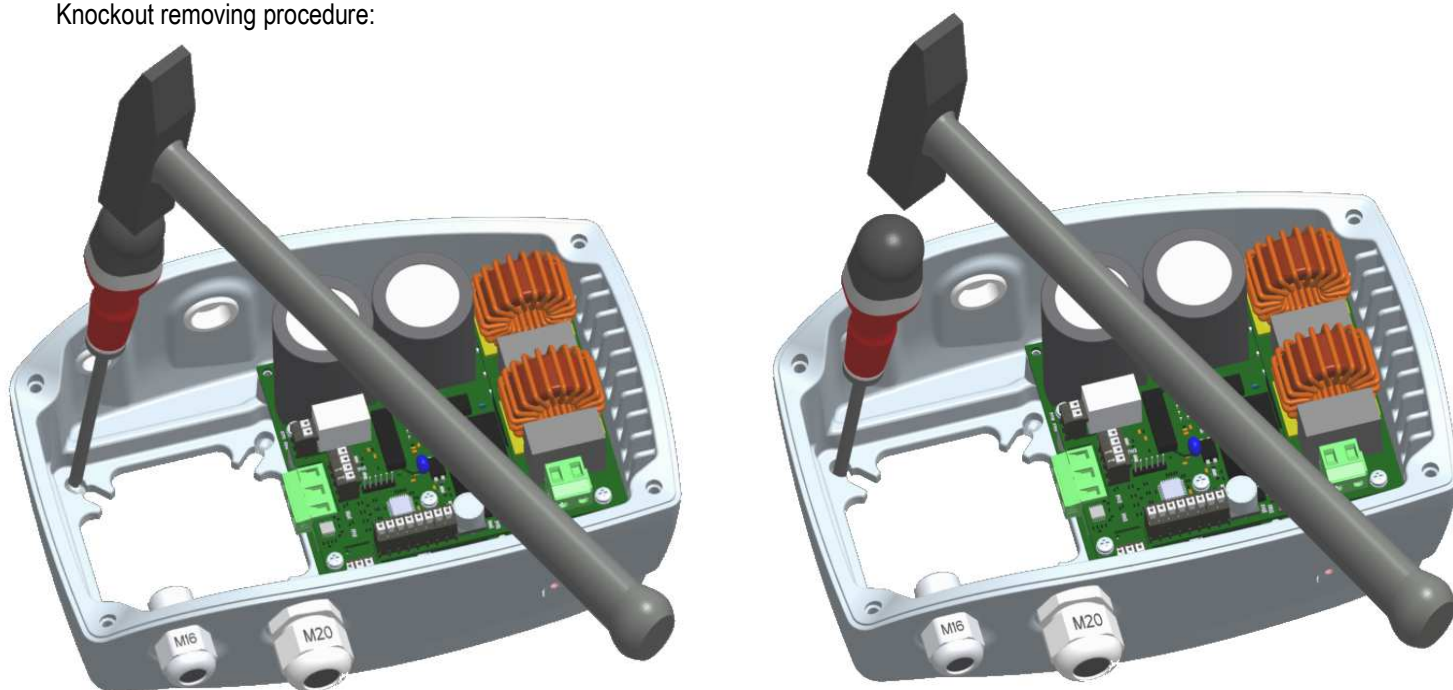

Be careful not to disperse metal or wire ends inside the housing of the inverter, that can create dangerous short-circuits.

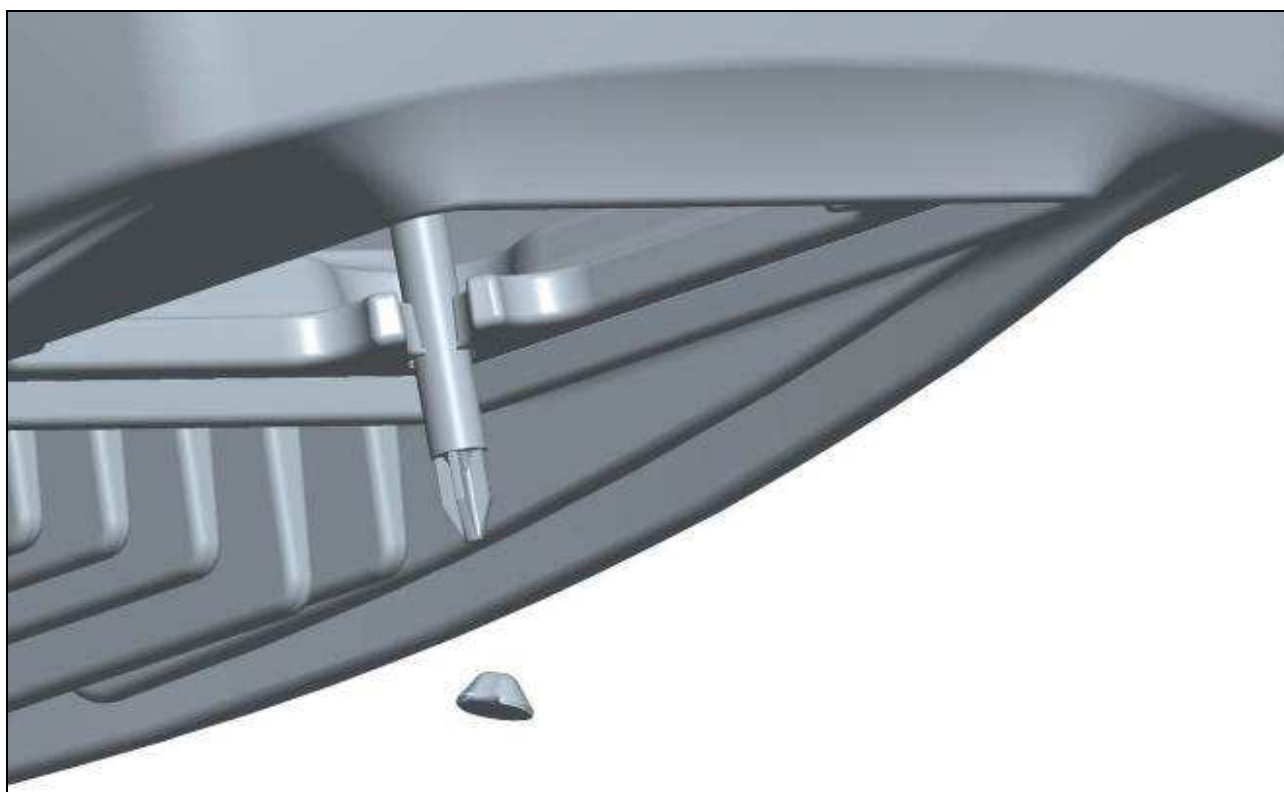

For the connection between NANO and the motors marked with X in the table "Tab. RD ", specific mechanical adapters are needed. See the following image.

63-71-80-90S-90L:

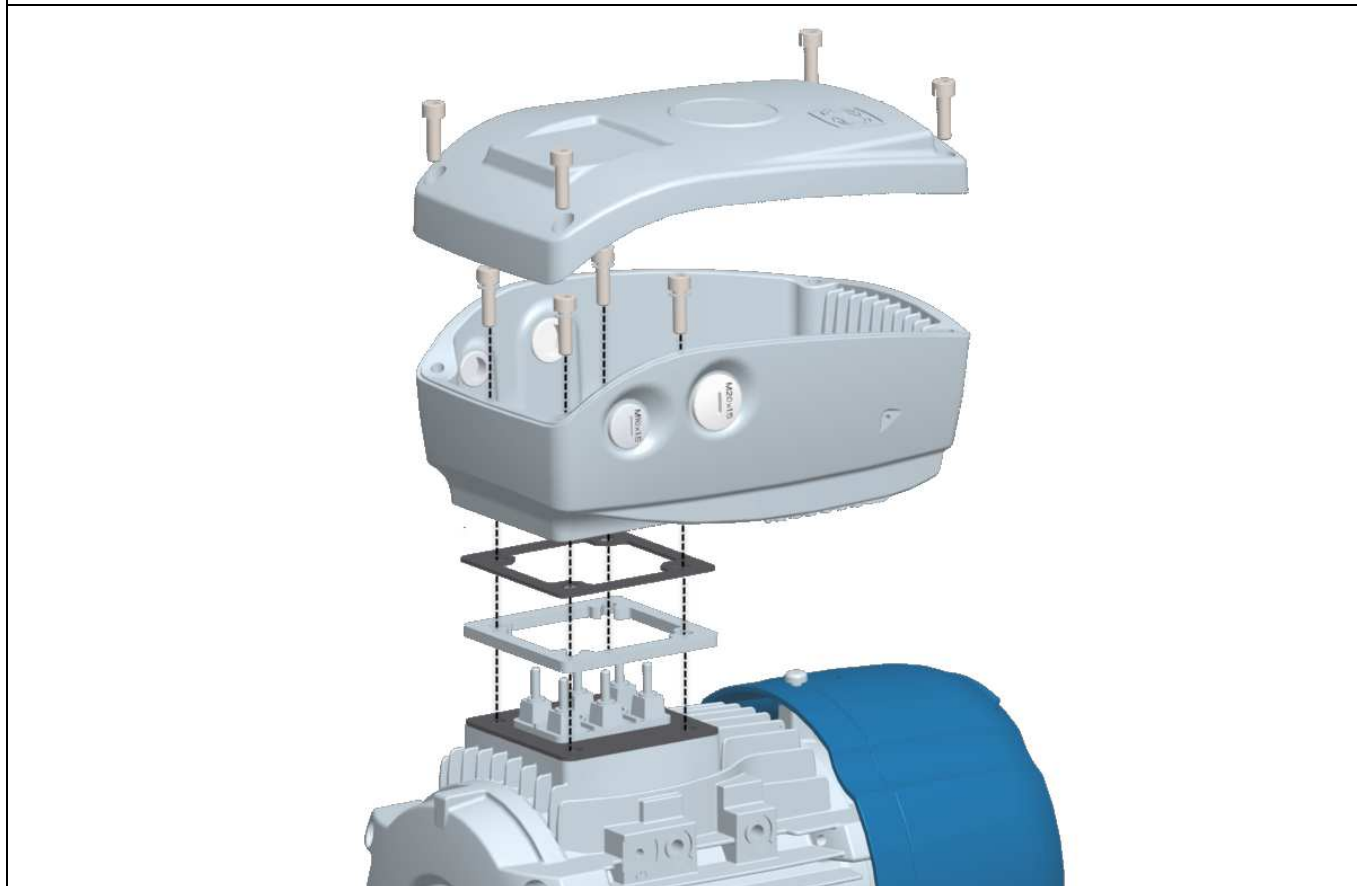

Table RD: Size range of IEC motors that can be connected



Do not lift or transport the motor connected to the inverter by gripping the inverter box.

4b.1 Forced Ventilation

If the inverter is used at frequencies lower than 50 Hz, it's necessary to use motors with forced ventilation:

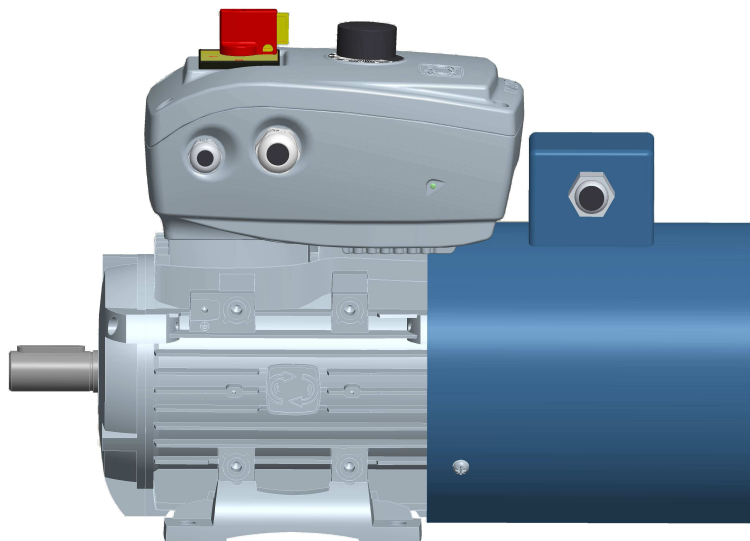

In some motor sizes (for example, IEC80), mechanical interference may occur between the forced ventilation terminals and the NANO housing.

In these cases the forced ventilation has to be turned through 90° as shown below:

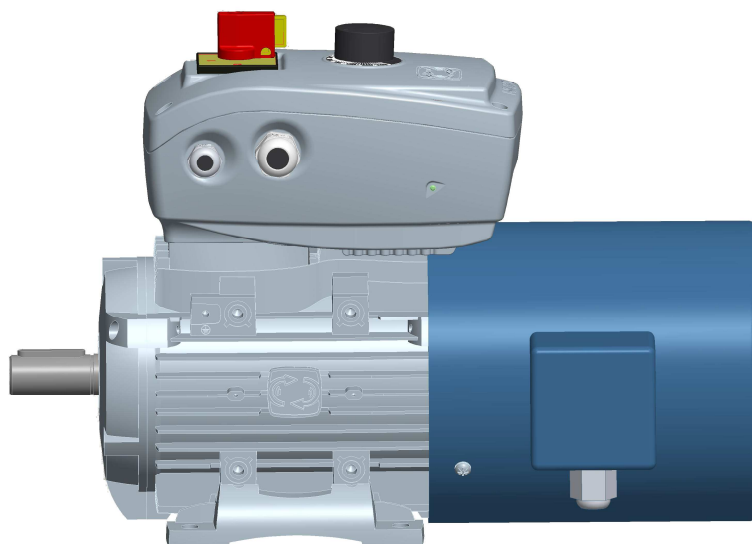

IEC Motor	63	71	80	90S	90L	100	112	132S
Position	↔	↔	↔	↔	↑	↑	↑	↑

4b.2 Brake motors manual release lever

In some sizes of brake motors, there may be mechanical interference between NANO and the brake release lever if positioned at the top. In these cases, the release lever can be disassembled by unscrewing it or, if it's useful to maintain it, it's necessary to rotate 90° (sizes 71-80), or 120° the NDE shield of the motor, together with the brake and fan cover. This operation can only be carried out by the factory or by centers authorized by Motive.

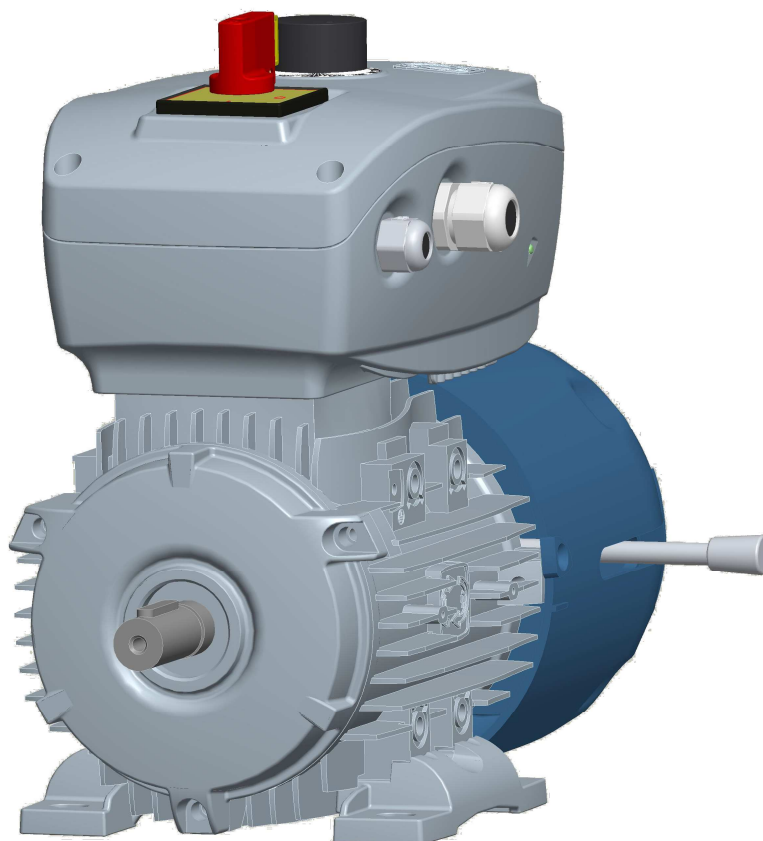

4c. Wall mounting (optional code WALL-NANO)

If a wall mounting is needed, such as for example for pumps control, you can use “WALL” system (mounting instructions and electrical connections provided with every kit).



5. ELECTRICAL ASSEMBLY

5a. Warnings



The installation must be carried out exclusively by qualified and expert personnel.

Any handling of the open Inverter box must be done at least 1 minute after the interruption of power, with an appropriate disconnect switch or by manually removing the power cable. To be certain that the internal capacitors are discharged, and that therefore maintenance can be performed, the internal LED located on the power module and visible on the outside through the special light guide must be completely turned off.

Always unplug NANO from the power outlet before handling any electrical or mechanical parts of the system.

Read this manual and the motor manual (download from www.motive.it) before installation.

In the event that the product has evident signs of damage, do not proceed with the installation and contact the Service Centre.

Strictly observe the safety and accident prevention regulations.

The mains voltage must match the one required by the inverter (Chap. 2).

- In conformity with the Machinery DIRECTIVE 2006/42/EC Section 1.2.4.3. it's necessary to install an emergency stop device that can be used as a backup to the stop solution provided by NANO. Such a device must be in a position from which the machine and its functioning is constantly and clearly visible.
- It's required that the system conforms to current safety regulations.
- Prepare an adequate general protection against short-circuits on the power line.
- Disconnect the power supply of the Inverter by acting on the upstream switch before opening its enclosure.

- EMC Directive requires that NANO power cables must be shielded (or armored) with single conductors with a cross section greater than or equal to 2.5 mm. The shielding of the conductors must be grounded at both ends.

To avoid ground loops that can cause radiated disturbance (antenna effect), the motor driven by NANO must be grounded individually, always with a low-impedance connection.

The paths of the main and motor-inverter power cords should be separated as much as possible. Do not create loops. If they should intersect, make sure it is at 90 degrees to produce the least coupling. Failure to comply with these conditions may completely or in part nullify the effect of the anti-disturbance filter.



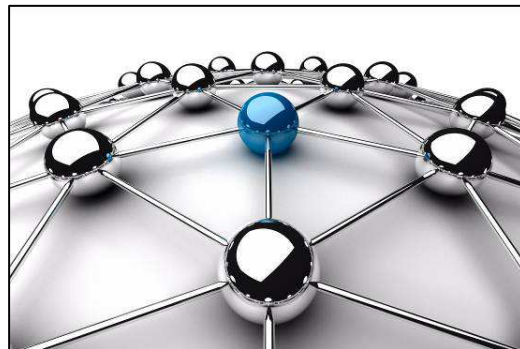



In some cases, to completely eliminate some disturbances (radiated or conducted) that other very sensitive plant equipment may be subject to, another EMC mains filter must be used, (Minimum rated current 10 amps) connected upstream, as input to the inverter.



5b. NANO electrical connection

- Open the inverter by unscrewing the cover screws;
- In presence of power switch and/or potentiometer, disconnect the wires from the side of the electronic card, remembering where they will then be reconnected;
- Connect the motor terminals to NANO as shown below

POWER SUPPLY - EXTERNAL DEVICES CONNECTION

	AC single phase power supply	Use the power supply within the limits allowed by the inverter
	▼ Earth leakage circuit breaker (differential)	Automatic differential switch with $I\Delta n=30mA$, type B . Type B differential switches are recommended for use with drives and inverters, since they recognize a continuous fault current with a low ripple rate.
	▼ Line power contactor	Useful to switch off the power supply if commanded by a safety circuit. Not to be used to start the system. Type AC1.
	▼ Protection fuses	A fuse is a protection against short circuits. Instead, a magneto-thermal switch would be an overload protection based on absorbed current, but this protection is already incorporated in NANO.
	▼ Line reactor	Useful for improving the power factor limiting the harmonics in line, or in the vicinity of large power systems (transformation cabins). Compulsory when the distance between motor and inverter (see wall mounting system) is higher than 50m
	▼ Motoinverter	The direct connection with the motor cancels the need for shielded cables compared to a conventional inverter. In case of using NANO not on board, use shielded cables and, if the distance to the motor exceeds 25mt, use a reactor in series.

5b.1 Dimensions of protection and safety devices

MOTOR POWER	RECOMMENDED FUSE 500VAC CL.H or K5	RECOMMENDED REACTOR	RECOMMENDED CONTACTOR	POWER CABLES SECTION mm ²
Up to 0,37kw at 230Vac	10A	2mH	25A	1,5
Up to 1,1kw at 230Vac	10A	2mH	25A	2,5
Up to 1,8kw at 230Vac	15A	2mH	25A	4
Up to 2,2kw at 230Vac	25A	1,25mH	45A	6
Up to 0,18kw at 110Vac	10A	2mH	25A	2,5
Up to 0,37kw at 110Vac	15A	2mH	25A	4
Up to 0,75kw at 110Vac	25A	1,25mH	45A	6

The short-circuit breaking capacity of devices paired with this range must be at least 10KA, if installed in public supply networks. In case of connection from a network coming from a dedicated transformer cabin, it is necessary to know the value declared by the supplier of the line and to use suitable devices.

- Ensure ground connection of the motoinverter with total resistance lower than 100Ω.

5b.2 Motor connection

NANO inverter must be installed on a three-phase asynchronous motor with power supply in the 115-240Vac 50/60 Hz range. Below, we show what to do with standard Motive Delphi line motors and ATDC brake-motors.



GROUNDING CONNECTION, important for the electrical safety of people and to suppress electromagnetic interference conducted in the mains:

- Yellow/green ground wire of the main supply cable to connect to one of four screws used to fix the inverter to the motor.

5b.3 Diagrams

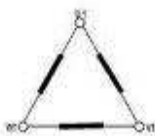

The motor phases are to be connected to delta  if the motor indicates on the plate 230V Δ / 400VY.

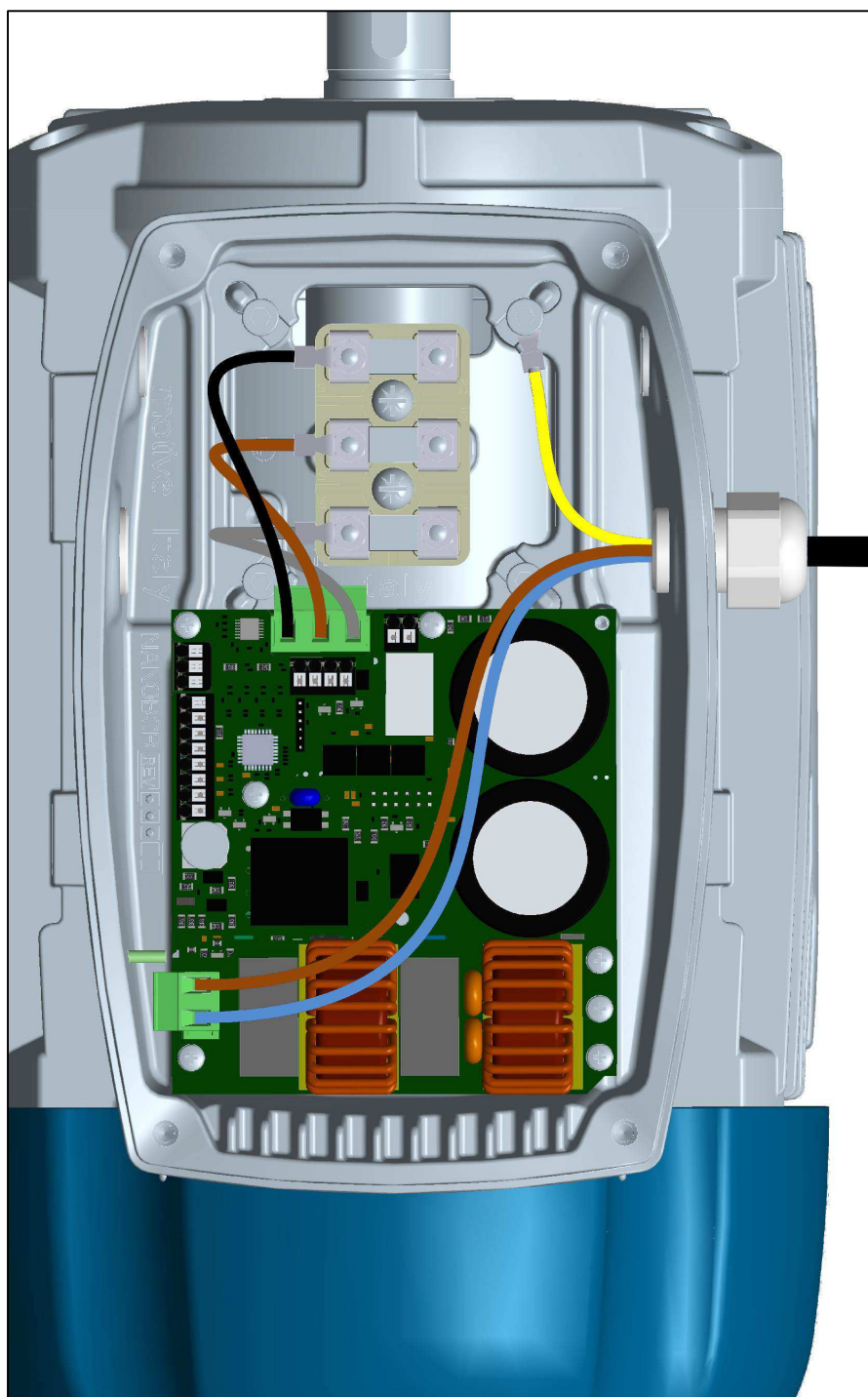

5c. General electric drawing 1^version

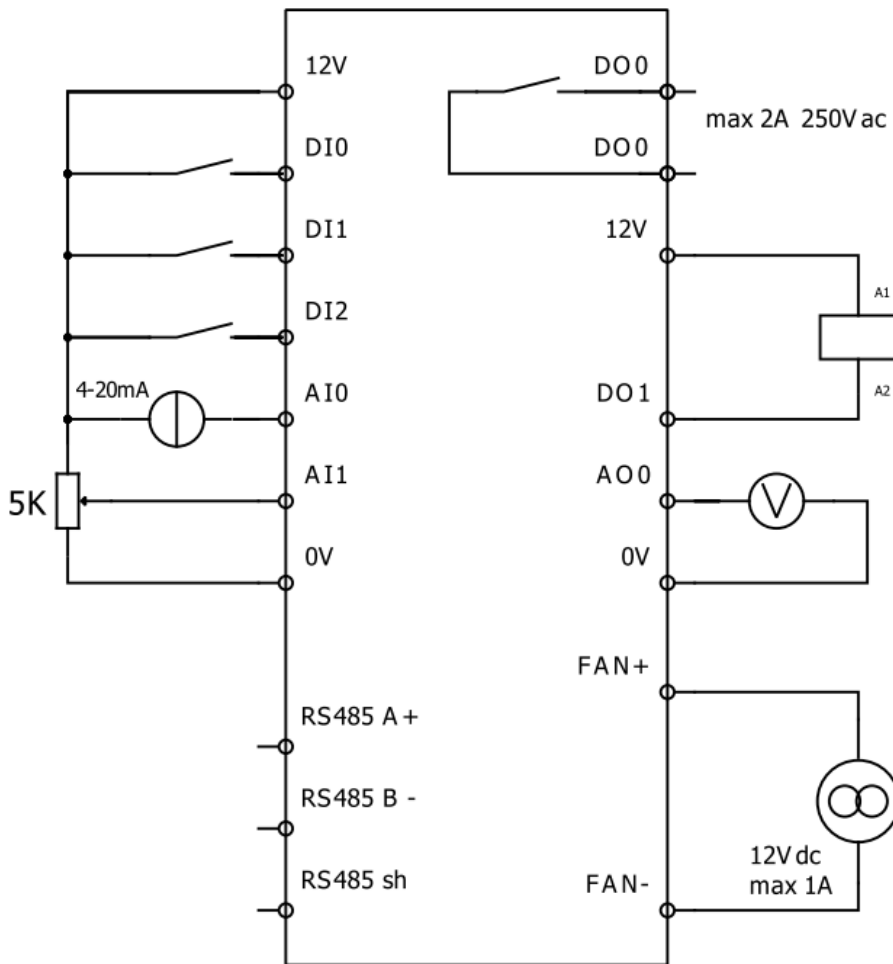
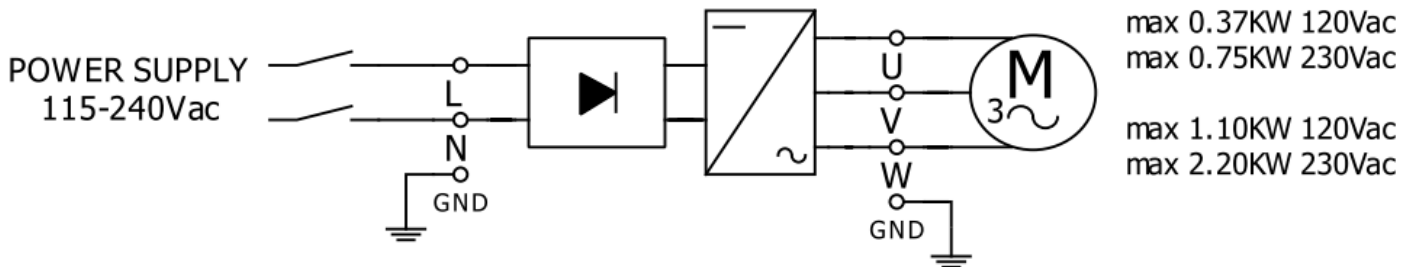

5c. General electric drawing 2[^]version

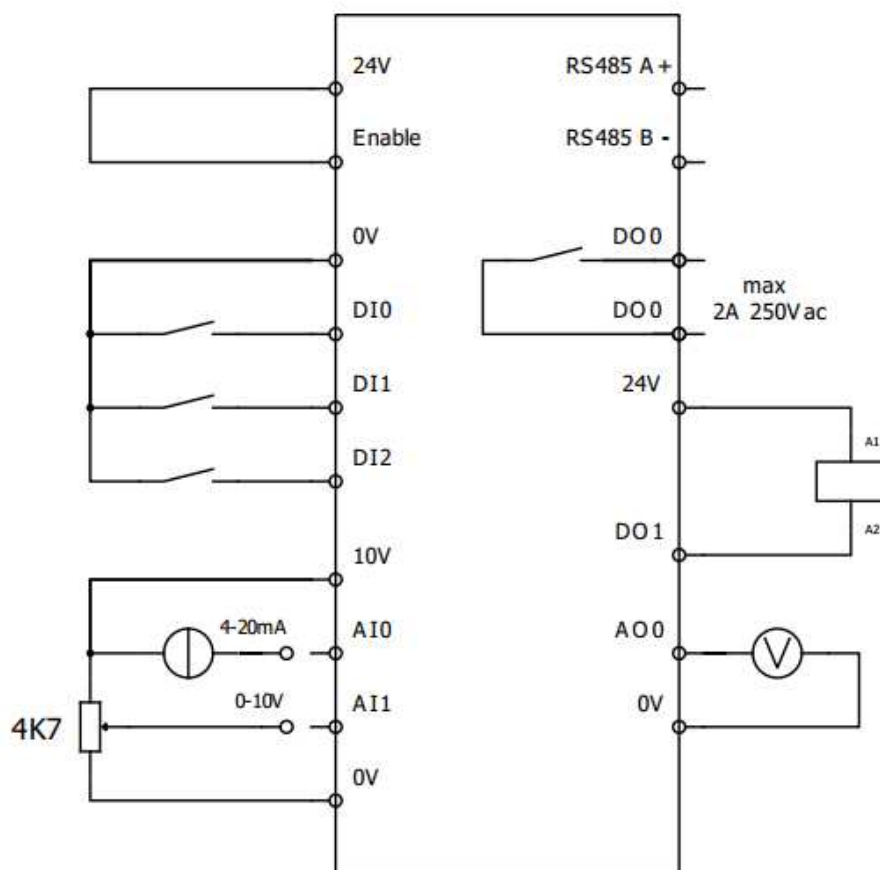
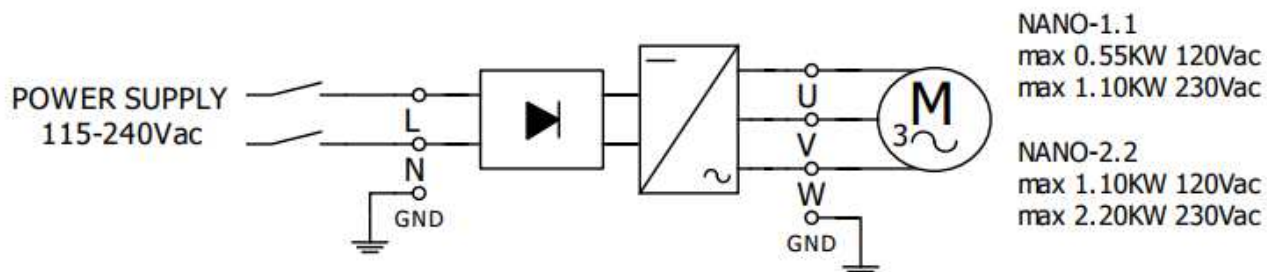

5d. External devices connection

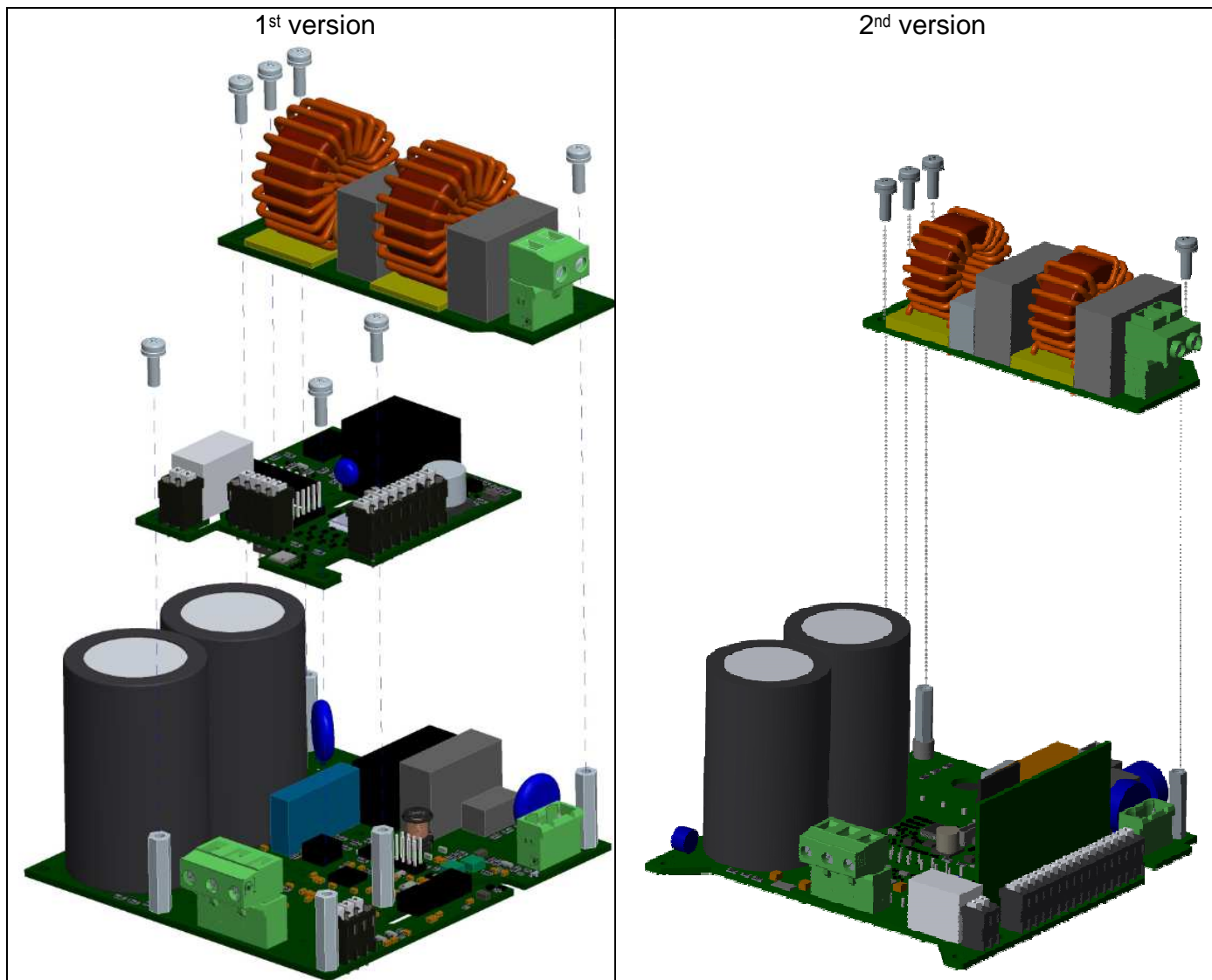

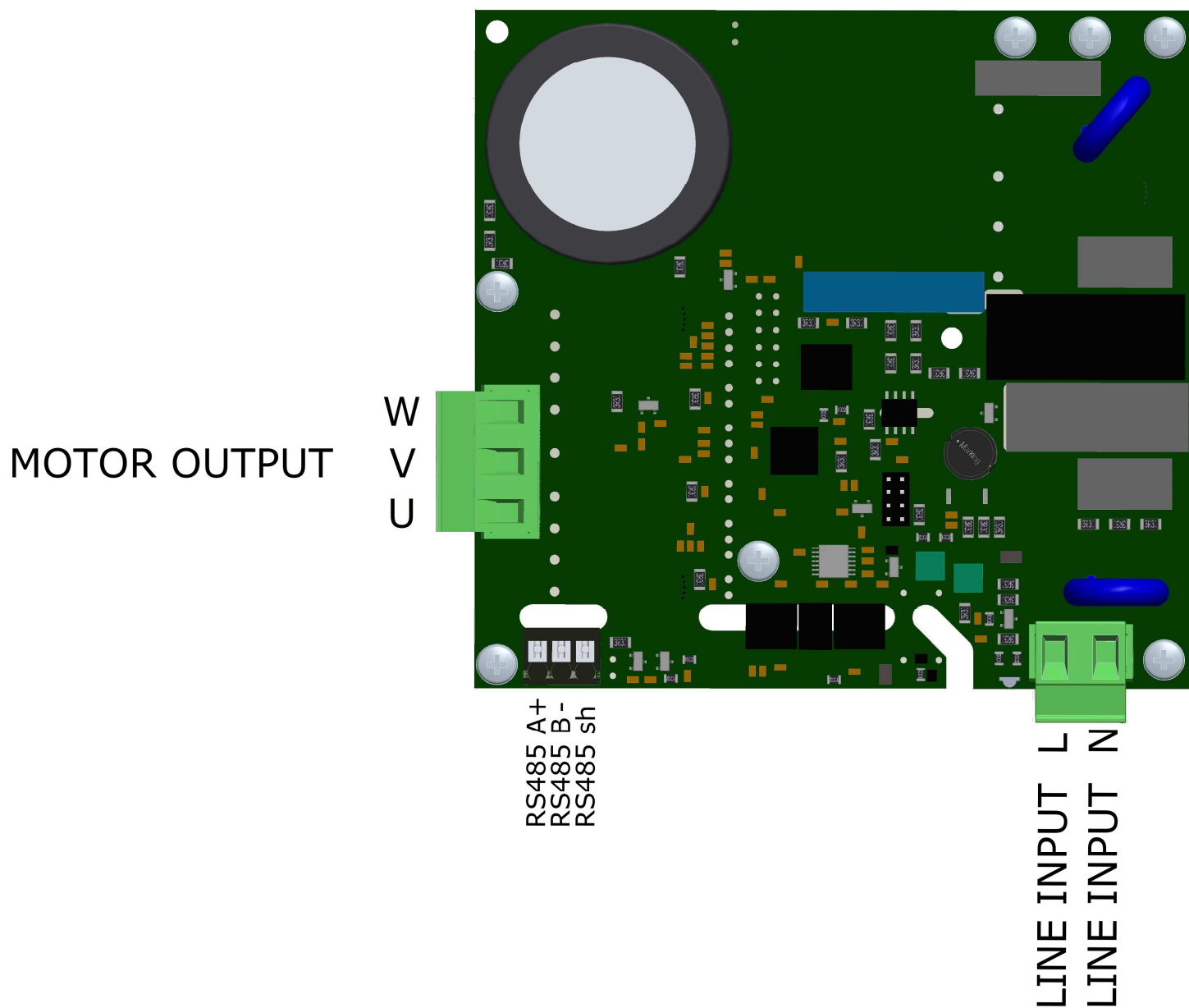

Figure (5) 1 – Power Module layout - [NANO-0,75](#) (Old version)

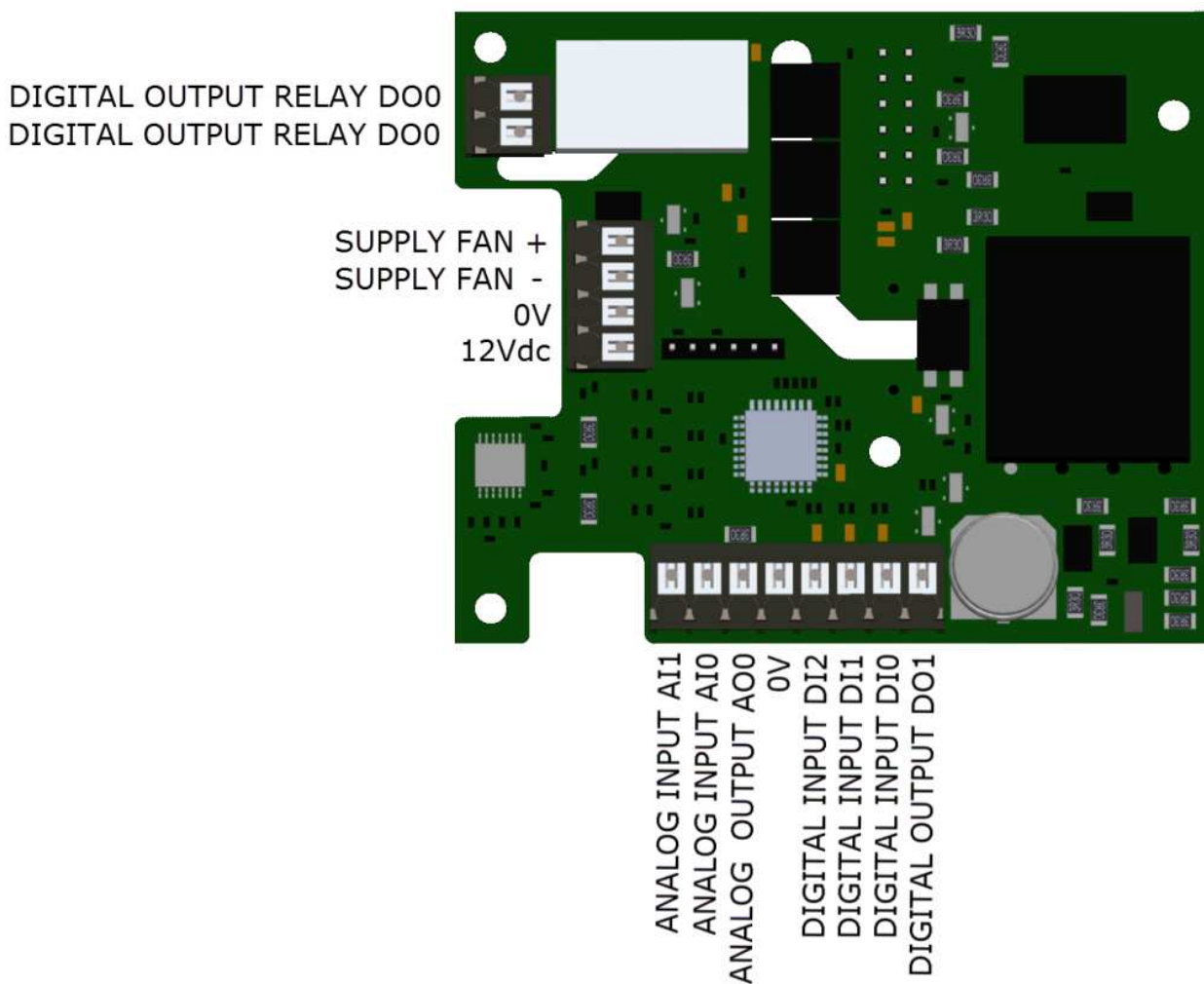

Figure (5) 4 - Analog/Digital I/O Module layout (1st version)*

* from November 2022, the Analog/Digital I/O Module is fitted as standard on all 1st version NANOs, and that until all 1st version NANOs run out. The NANO-2,2 2nd version and all NANO-1,1 have this device already incorporated in the power module

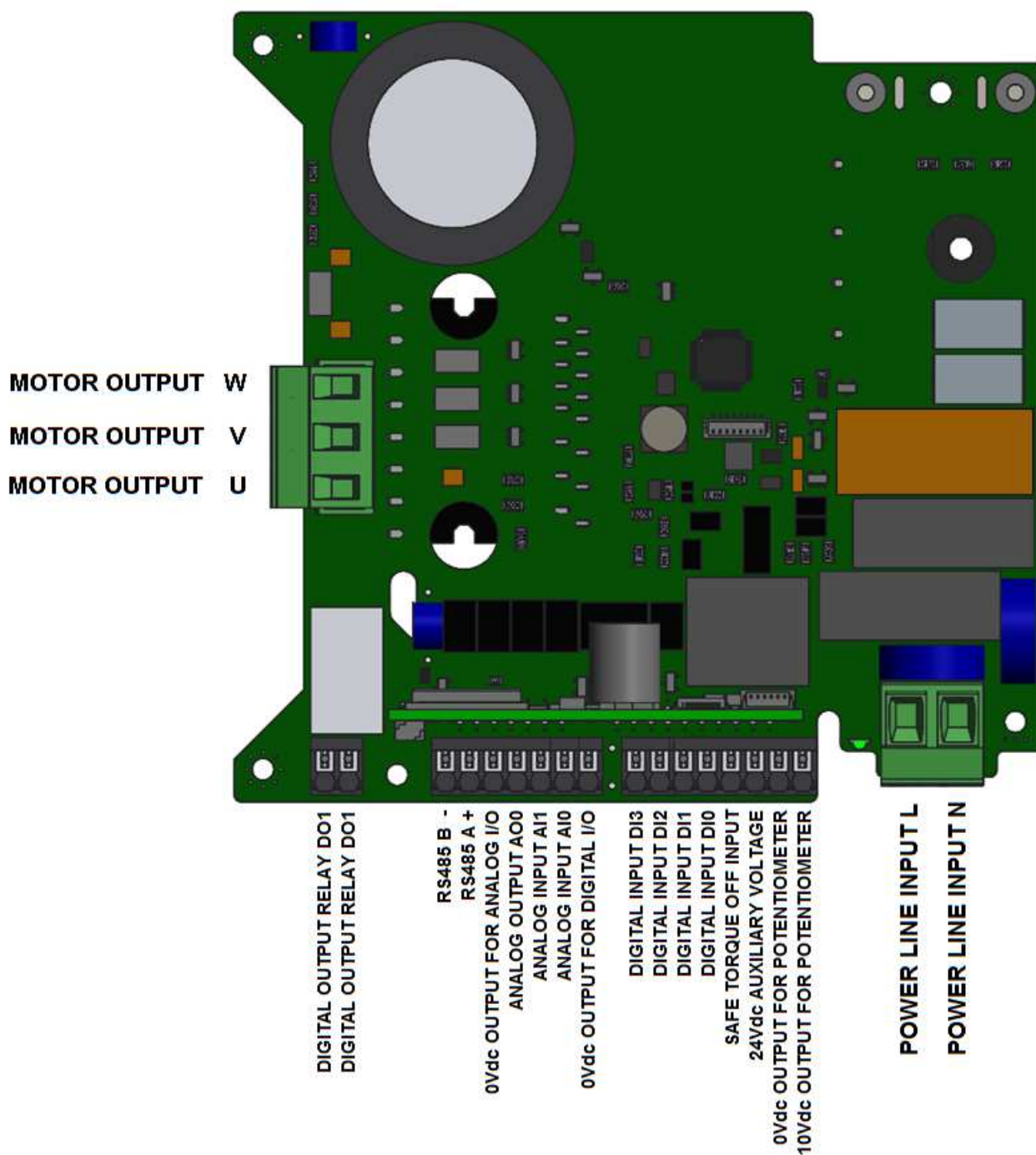

Figure (5) 1 – Power Module layout - [NANO-1,1](#)

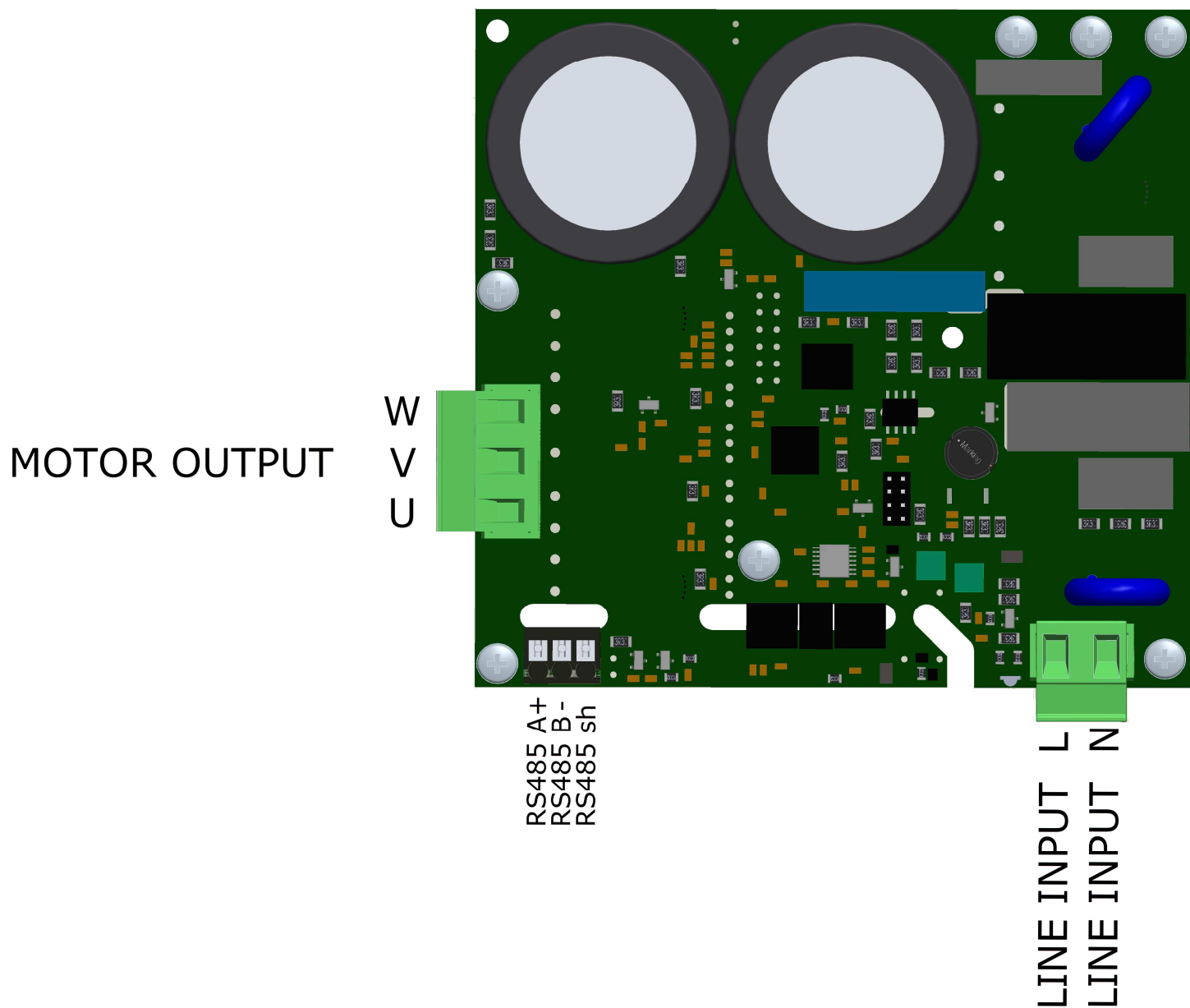

Figure (5) 1 – Power Module layout - [NANO-2,2](#) (1st version)*

* The 1st version of the NANO-2.2 is running out. As soon as it is finished, the 2nd version will go into production, and that's expected during 2023

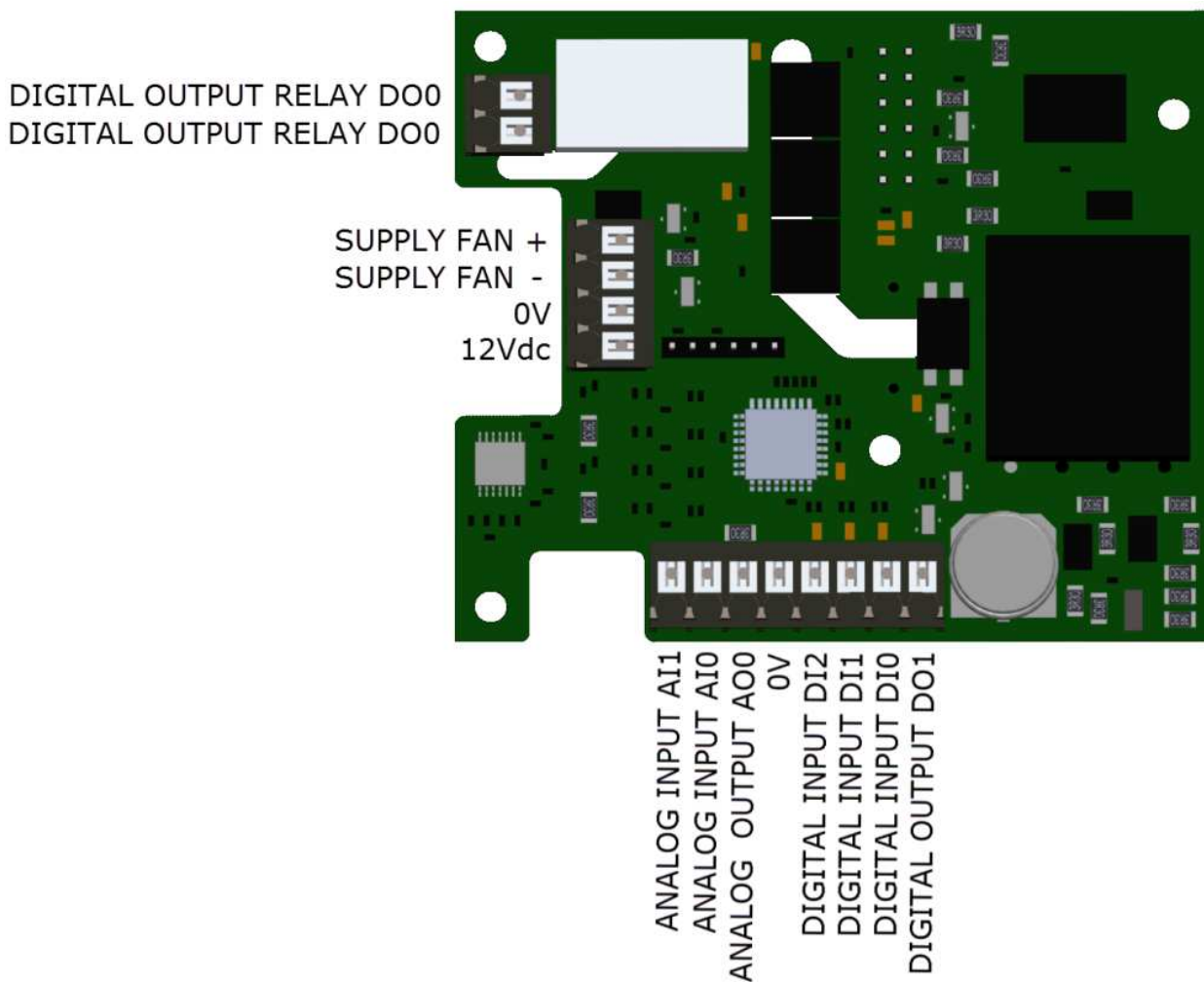

Figure (5) 4 - Analog/Digital I/O Module layout (1st version)

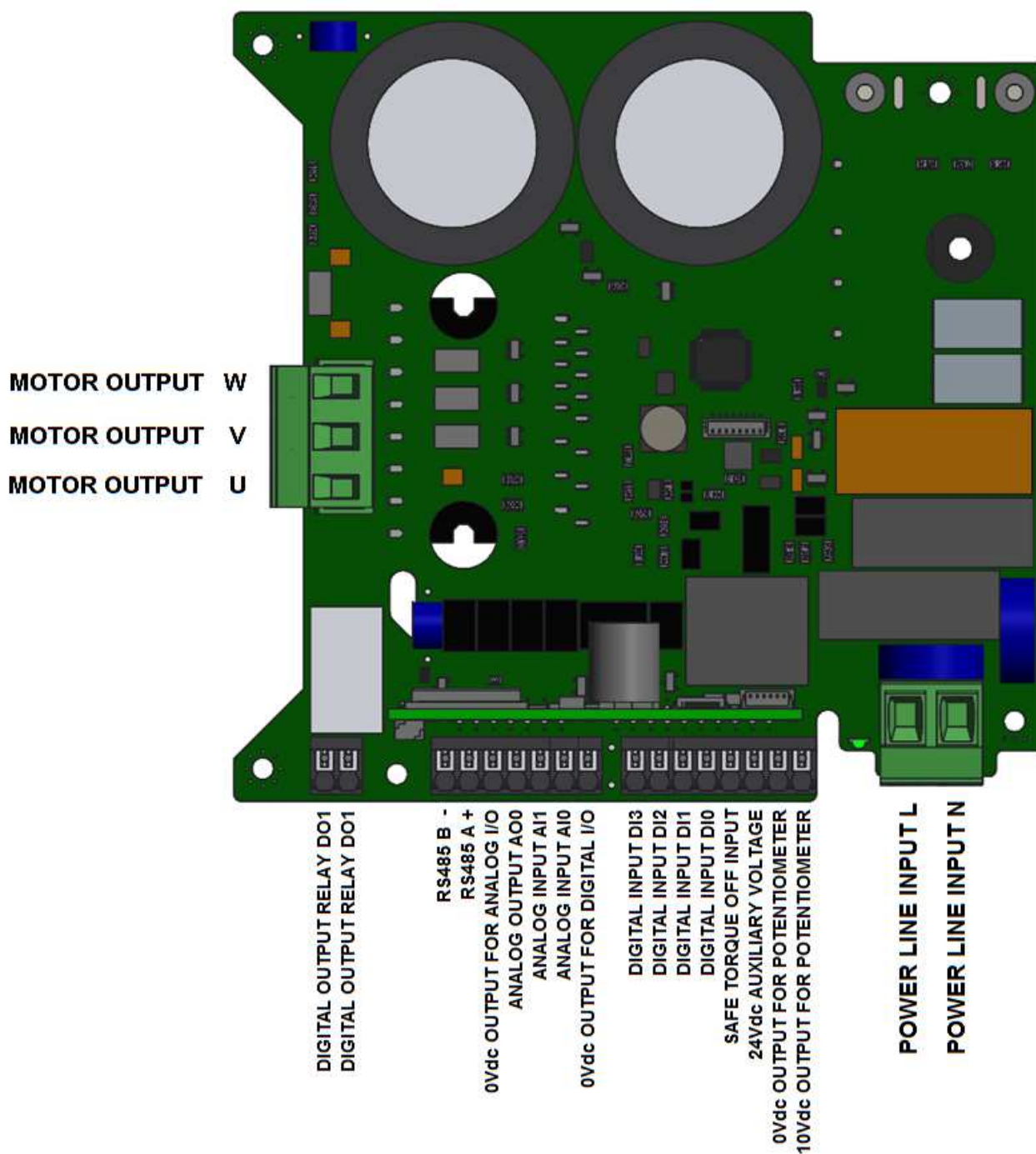

Figure (5) 1 – Power Module layout - [NANO-2,2](#) (2nd version)

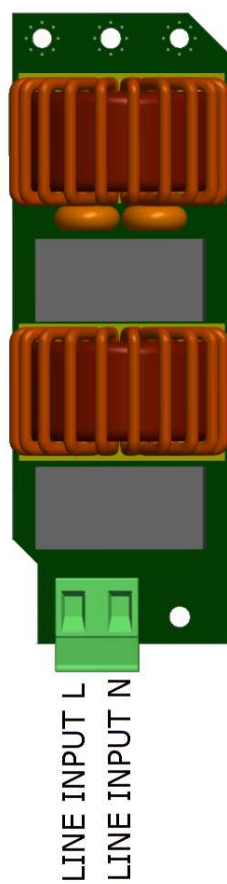
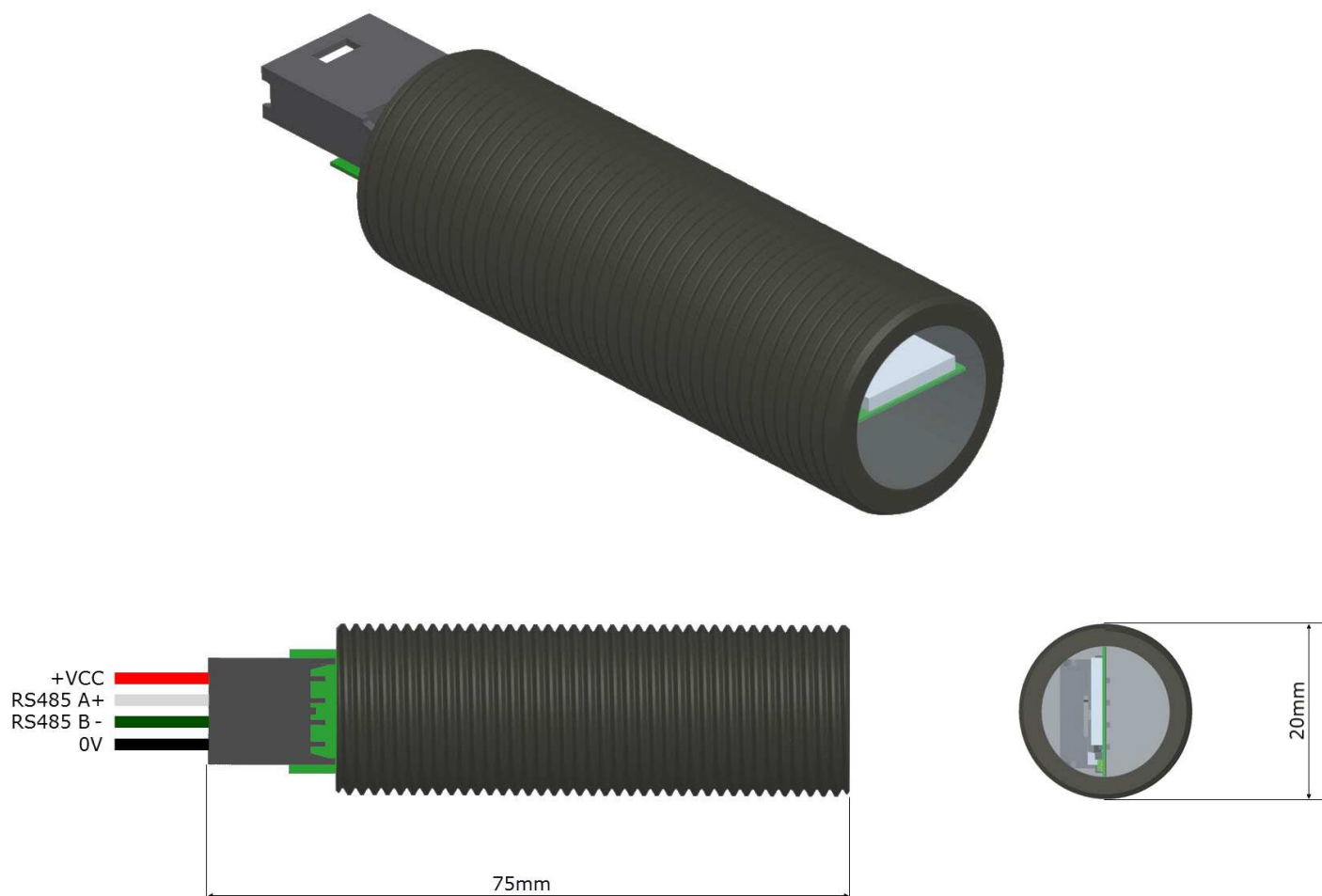
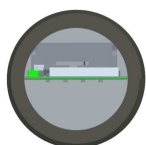

Figure (5) 3 - EMC filter layout (optional code NANFILT.1)



Functioning



Steady green light: BLUE is powered correctly, waiting for connection to your device

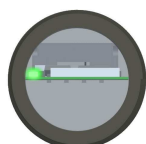

Flashing green light: BLUE is connected to your device

Figure (5) 5 - Bluetooth module for smartphone and tablet control (optional code BLUE)

NANO-0,75 (old version) and NANO-2,2 (1st version)

Terminal	Function
L	Supply inverter phase.
N	Supply inverter neutral phase.
U	U phase motor connection.
V	V phase motor connection.
W	W phase motor connection.
A+	High signal ModBus RS485.
B-	Low signal ModBus RS485.
sh	Ground for Modbus RS485 cable shield.

Analog/Digital I/O Module (1st version)

0V	0Vdc supply.
12Vdc	12Vdc supply for all the electronic Inputs (analogic e digital) and DO1 Digital Output.
FAN +	12Vdc supply (max 1A) for inverter ventilation.
FAN -	It's automatically enabled when the IGBT module starts to overheat.
Ai0	Analog Input 0, programmable in the following functions: <ul style="list-style-type: none"> • speed reference with potentiometer; • speed reference with external signal; • current limit reference; • PID feedback (for example: connection of a transducer). The type of input signal can be in voltage (0-10V) or in current (4-20mA).
Ai1	Analog Input 1, programmable in the following functions: <ul style="list-style-type: none"> • speed reference with potentiometer; • speed reference with external signal; • current limit reference; • PID feedback (for example: connection of a transducer). The type of input signal can be in voltage (0-10V) or in current (4-20mA).
Ao0	Analog Output 0, programmable in the following functions: <ul style="list-style-type: none"> • 0-10V motor speed reference (from 0% to the maximum speed value set); • 0-10V motor current absorbed reference (from 0% to the maximum absorption set).
0V	0Vdc supply for Ao0 Analogic Output.
Di0	Digital Input 0, programmable in the following functions: <ul style="list-style-type: none"> • Start/Stop motor command clockwise direction (1=Start, 0=Stop); • Start/Brake motor command (1=Start, 0=Brake); • reverse motor command (it works only when Start/Stop motor command is set to a Digital Input with value=1); • brake motor command (can also be used as an inverter enable or as an emergency stop); • Start/Stop motor command counter-clockwise direction (1=Start, 0=Stop).
Di1	Digital Input 1, programmable in the following functions: <ul style="list-style-type: none"> • Start/Stop motor command clockwise direction (1=Start, 0=Stop); • Start/Brake motor command (1=Start, 0=Brake); • reverse motor command (it works only when Start/Stop motor command is set to a Digital Input with value=1); • brake motor command (can also be used as an inverter enable or as an emergency stop); • Start/Stop motor command counter-clockwise direction (1=Start, 0=Stop).

DI2	Digital Input 2, programmable in the following functions: <ul style="list-style-type: none"> • Start/Stop motor command clockwise direction (1=Start, 0=Stop); • Start/Brake motor command (1=Start, 0=Brake); • reverse motor command (it works only when Start/Stop motor command is set to a Digital Input with value=1); • brake motor command (can also be used as an inverter enable or as an emergency stop); • Start/Stop motor command counter-clockwise direction (1=Start, 0=Stop).
DO0	Digital Output 0 N.O. contact, programmable in the following functions: <ul style="list-style-type: none"> • signaling when the motor is running; • signaling of the motor rotation sense (0=clockwise, 1=counter-clockwise); • signaling maximum speed reached; • motoinverter fault; • signaling when the motor is stopped; • load/unload electric valve control (air compressor mode).
DO1	Digital Output 1, programmable in the following functions: <ul style="list-style-type: none"> • signaling when the motor is running; • signaling of the motor rotation sense (0=clockwise, 1=counter-clockwise); • signaling maximum speed reached; • motoinverter fault; • signaling when the motor is stopped; • load/unload electric valve control (air compressor mode). When is enabled, DO1 Digital Output supplies 0Vdc signal: this signal can be used to drive a relay (use the 12Vdc supplied by the inverter).

NANO-1,1 and NANO-2,2 (2nd version)

Terminal	Function
L	Supply inverter phase.
N	Supply inverter neutral phase.
U	U phase motor connection.
V	V phase motor connection.
W	W phase motor connection.
A+	High signal ModBus RS485.
B-	Low signal ModBus RS485.
10Vdc	10Vdc supply for potentiometer
0V	0Vdc supply for potentiometer
24Vdc	24Vdc supply for all the electronic Inputs (analogic e digital) and DO1 Digital Output.
S.T.O.	Input Safe Torque Off (future version)
S.T.O.	Input Safe Torque Off (future version)
Enable	Enable the inverter when closed to 24V (will be replace by S.T.O.)
DI0	Digital Input 0, power supply both 0Vdc and 24Vdc, programmable in the following functions: <ul style="list-style-type: none"> • Start/Stop motor command clockwise direction (1=Start, 0=Stop); • Start/Brake motor command (1=Start, 0=Brake); • reverse motor command (it works only when Start/Stop motor command is set to a Digital Input with value=1); • brake motor command (can also be used as an inverter enable or as an emergency stop); • Start/Stop motor command counter-clockwise direction (1=Start, 0=Stop).
DI1	Digital Input 1, power supply both 0Vdc and 24Vdc, programmable in the following functions: <ul style="list-style-type: none"> • Start/Stop motor command clockwise direction (1=Start, 0=Stop); • Start/Brake motor command (1=Start, 0=Brake); • reverse motor command (it works only when Start/Stop motor command is set to a Digital Input with value=1); • brake motor command (can also be used as an inverter enable or as an emergency stop); • Start/Stop motor command counter-clockwise direction (1=Start, 0=Stop).
DI2	Digital Input 2, power supply both 0Vdc and 24Vdc, programmable in the following functions: <ul style="list-style-type: none"> • Start/Stop motor command clockwise direction (1=Start, 0=Stop); • Start/Brake motor command (1=Start, 0=Brake); • reverse motor command (it works only when Start/Stop motor command is set to a Digital Input with value=1); • brake motor command (can also be used as an inverter enable or as an emergency stop); • Start/Stop motor command counter-clockwise direction (1=Start, 0=Stop).
DI3	Digital Input 3, power supply both 0Vdc and 24Vdc, programmable in the following functions: <ul style="list-style-type: none"> • Start/Stop motor command clockwise direction (1=Start, 0=Stop); • Start/Brake motor command (1=Start, 0=Brake); • reverse motor command (it works only when Start/Stop motor command is set to a Digital Input with value=1); • brake motor command (can also be used as an inverter enable or as an emergency stop); • Start/Stop motor command counter-clockwise direction (1=Start, 0=Stop).
0V	0Vdc supply for digital inputs.

AIO	Analog Input 0, programmable in the following functions: <ul style="list-style-type: none"> • speed reference with potentiometer; • speed reference with external signal; • current limit reference; • PID feedback (for example: connection of a transducer). The type of input signal can be in voltage (0-10V) or in current (4-20mA).
A11	Analog Input 1, programmable in the following functions: <ul style="list-style-type: none"> • speed reference with potentiometer; • speed reference with external signal; • current limit reference; • PID feedback (for example: connection of a transducer). The type of input signal can be in voltage (0-10V) or in current (4-20mA).
AO0	Analog Output 0, programmable in the following functions: <ul style="list-style-type: none"> • 0-10V motor speed reference (from 0% to the maximum speed value set); • 0-10V motor current absorbed reference (from 0% to the maximum absorption set).
0V	0Vdc supply for AO0 Analogic Output.
DO0	Digital Output 0 N.O. contact, programmable in the following functions: <ul style="list-style-type: none"> • signaling when the motor is running; • signaling of the motor rotation sense (0=clockwise, 1=counter-clockwise); • signaling maximum speed reached; • motoinverter fault; • signaling when the motor is stopped; • load/unload electric valve control (air compressor mode).

5d.1 Examples

- To start the motor automatically as soon as the inverter is powered, program an available digital input (for example DI2) as follows:

Parameter 45 “Digital input 2 function setup” → Start/Stop motor command clockwise direction
(if it's required the clockwise rotation);

→ Start/Stop motor command counter-clockwise direction
(if it's required the counter-clockwise rotation);

Parameter 23 “Enable restart” → 1 (Enabled).

Then connect the I/O Module terminals as follows (Fig. COM0):

12Vdc terminal to the DI2 terminal of I/O Module.

Fig. COM0

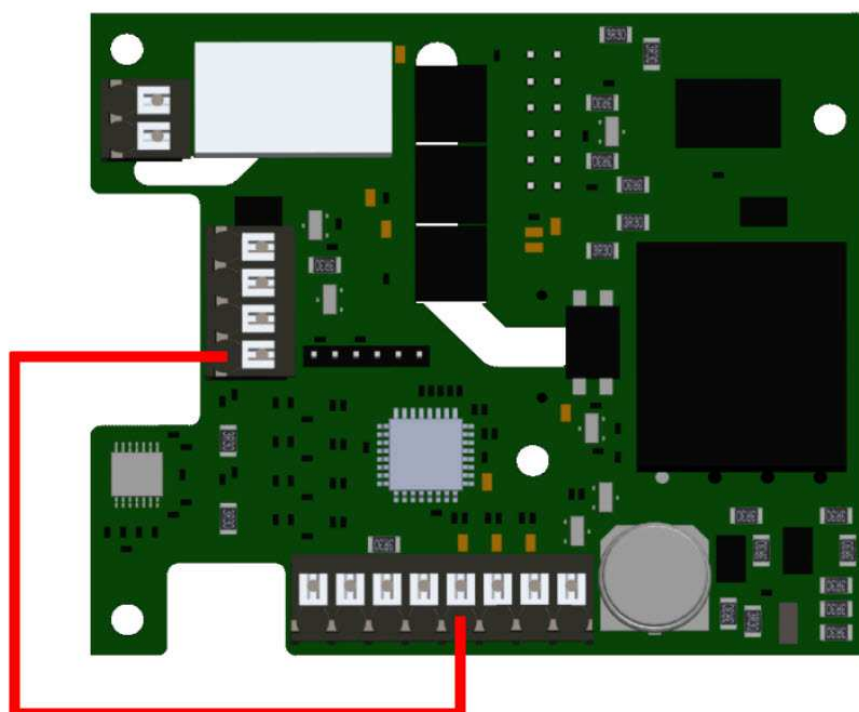

- To start the motor automatically as soon as the inverter is powered, program an available digital input (for example DI2) as follows:
Parameter 45 “Digital input 2 function setup” → Start/Stop motor command clockwise direction
(if it's required the clockwise rotation);
→ Start/Stop motor command counter-clockwise direction
(if it's required the counter-clockwise rotation);
Parameter 23 “Enable restart” → 1 (Enabled).

Then connect the I/O Module terminals as follows (Fig. COM0):
0Vdc terminal to the DI2 terminal of I/O Module.

Fig. COM0

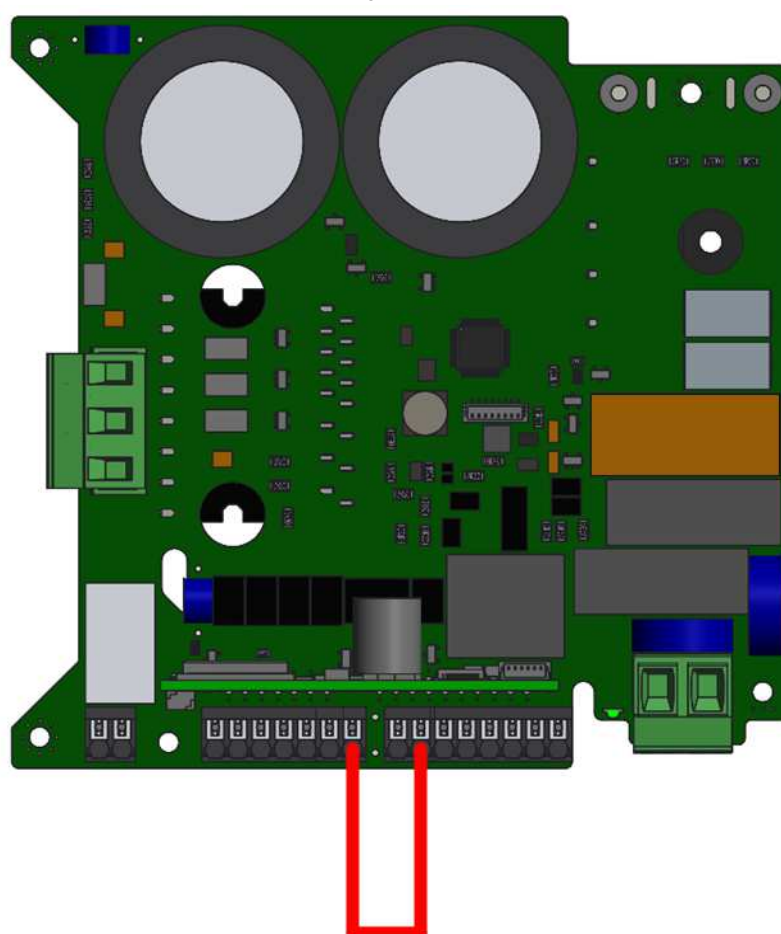

- To control the running and the rotation in local mode, it's possible to use a switch with 3 fixed positions (1-0-2). Program two available Digital Inputs (for example DI1 and DI0) as follows:
Parameter 44 "Digital Input 1 function setup" → Start/Stop motor command clockwise direction;
Parameter 43 "Digital Input 0 function setup" → Start/Stop motor command counter-clockwise direction.

Then connect the switch pins to the I/O module (Fig. COM1):

12Vdc terminal to the switch pin 0;

DI0 terminal to the switch pin 2;

DI1 terminal to the switch pin 1.

Fig. COM1

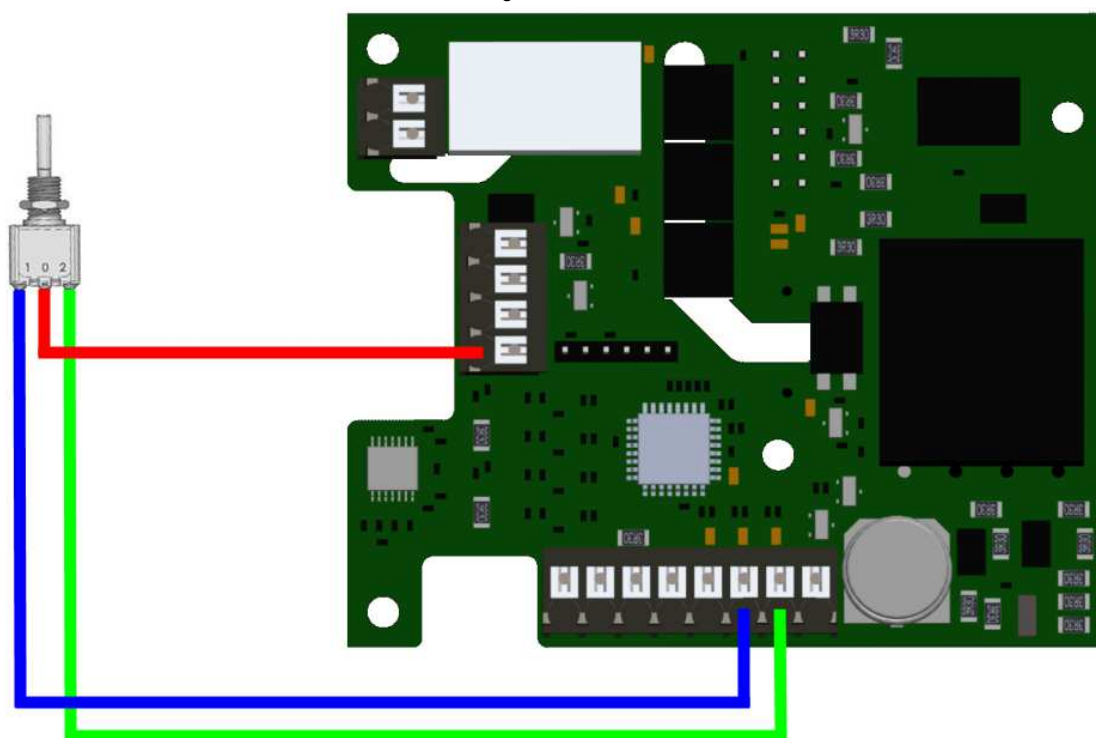

- To control the running and the rotation in local mode, it's possible to use a switch with 3 fixed positions (1-0-2). Program two available Digital Inputs (for example DI1 and DI0) as follows:
Parameter 44 "Digital Input 1 function setup" → Start/Stop motor command clockwise direction;
Parameter 43 "Digital Input 0 function setup" → Start/Stop motor command counter-clockwise direction.

Then connect the switch pins to the I/O module (Fig. COM1):

0Vdc terminal to the switch pin 0;

DI0 terminal to the switch pin 2;

DI1 terminal to the switch pin 1.

Fig. COM1

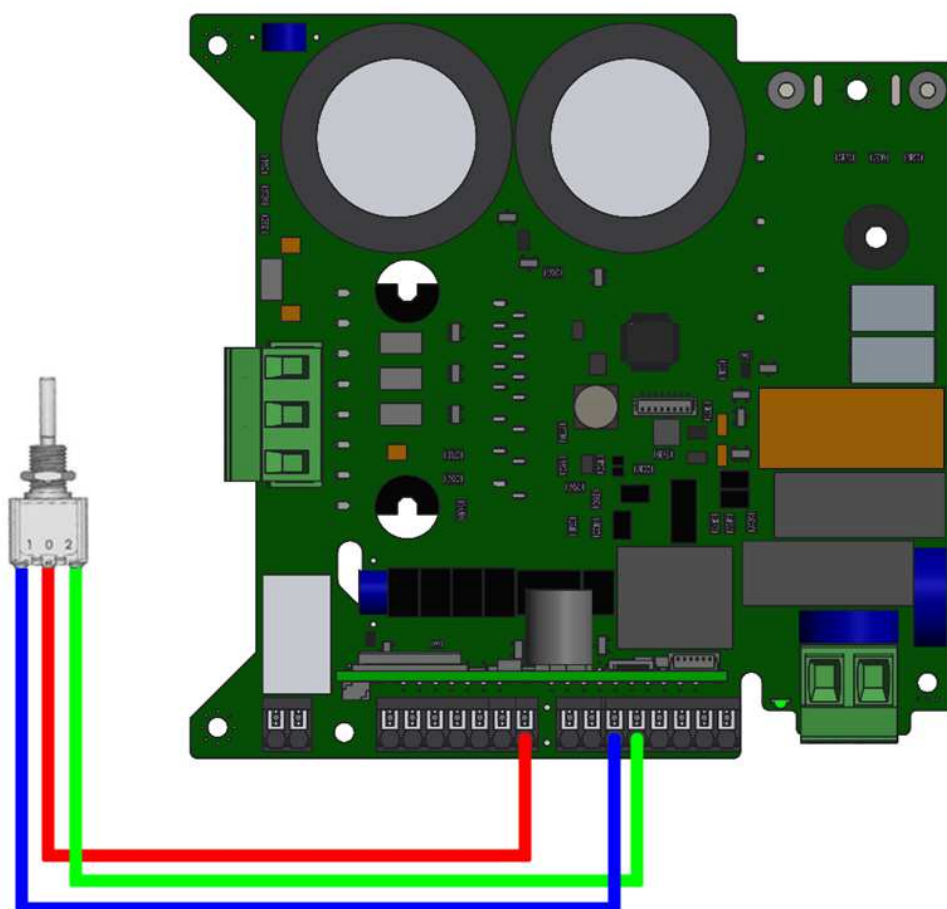

- To change the motor speed in local mode, it's possible to use a 4.7K Ω potentiometer (optional code NANPOT).
Program an available Analog Input (for example AI1) as follows:
Parameter 51 "Analog Input 1 function setup" \rightarrow Speed reference with potentiometer;
Parameter 26 "Input Signal" \rightarrow 1 (=Analog input);
Parameter 28 "Analog Input 1 Setup" \rightarrow 0 (=0/10V).

Then connect the potentiometer pins to the I/O module (Fig. COM2):
12Vdc terminal to the potentiometer pin 3;
0Vdc terminal to the potentiometer pin 1;
AI1 terminal to the potentiometer pin 2.

Fig. COM2

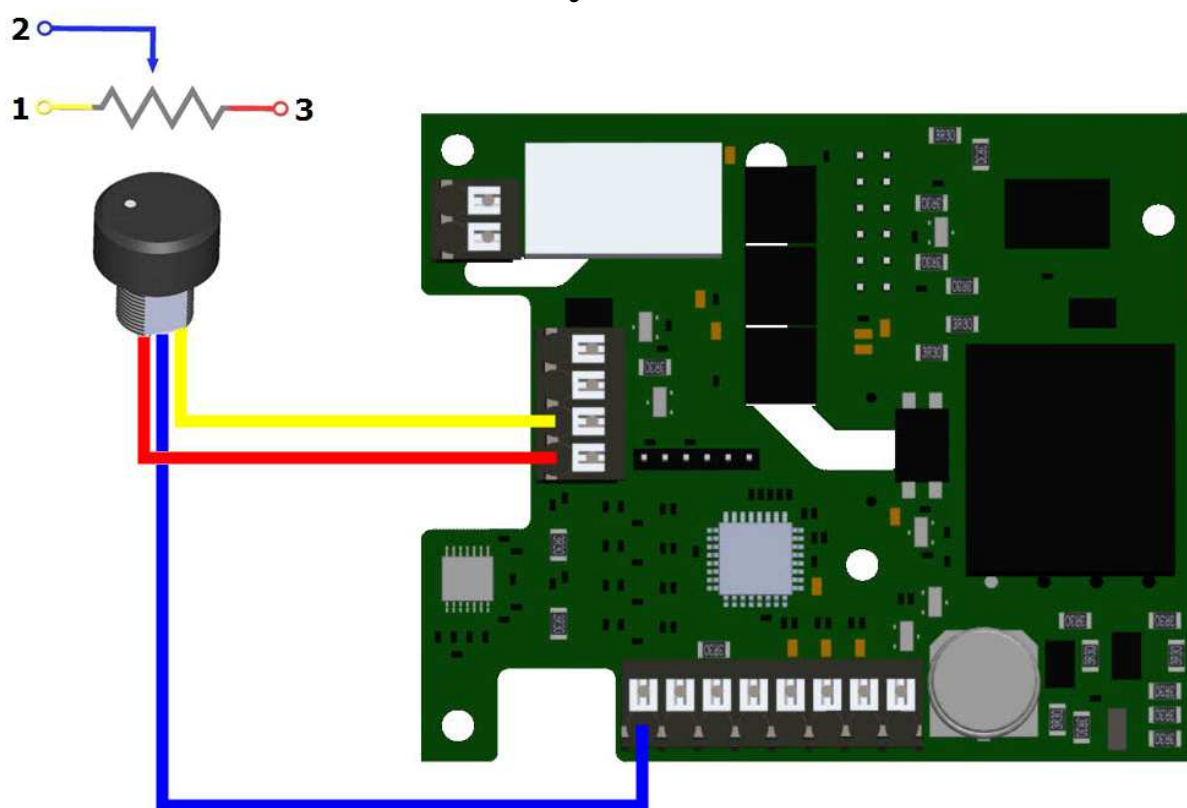

- To change the motor speed in local mode, it's possible to use a 4.7K Ω potentiometer (optional code NANPOT).
Program an available Analog Input (for example AI1) as follows:
Parameter 51 "Analog Input 1 function setup" \rightarrow Speed reference with potentiometer;
Parameter 26 "Input Signal" \rightarrow 1 (=Analog input);
Parameter 28 "Analog Input 1 Setup" \rightarrow 0 (=0/10V).

Then connect the potentiometer pins to the I/O module (Fig. COM2):
10Vdc terminal to the potentiometer pin 3;
0Vdc terminal to the potentiometer pin 1;
AI1 terminal to the potentiometer pin 2.

Fig. COM2

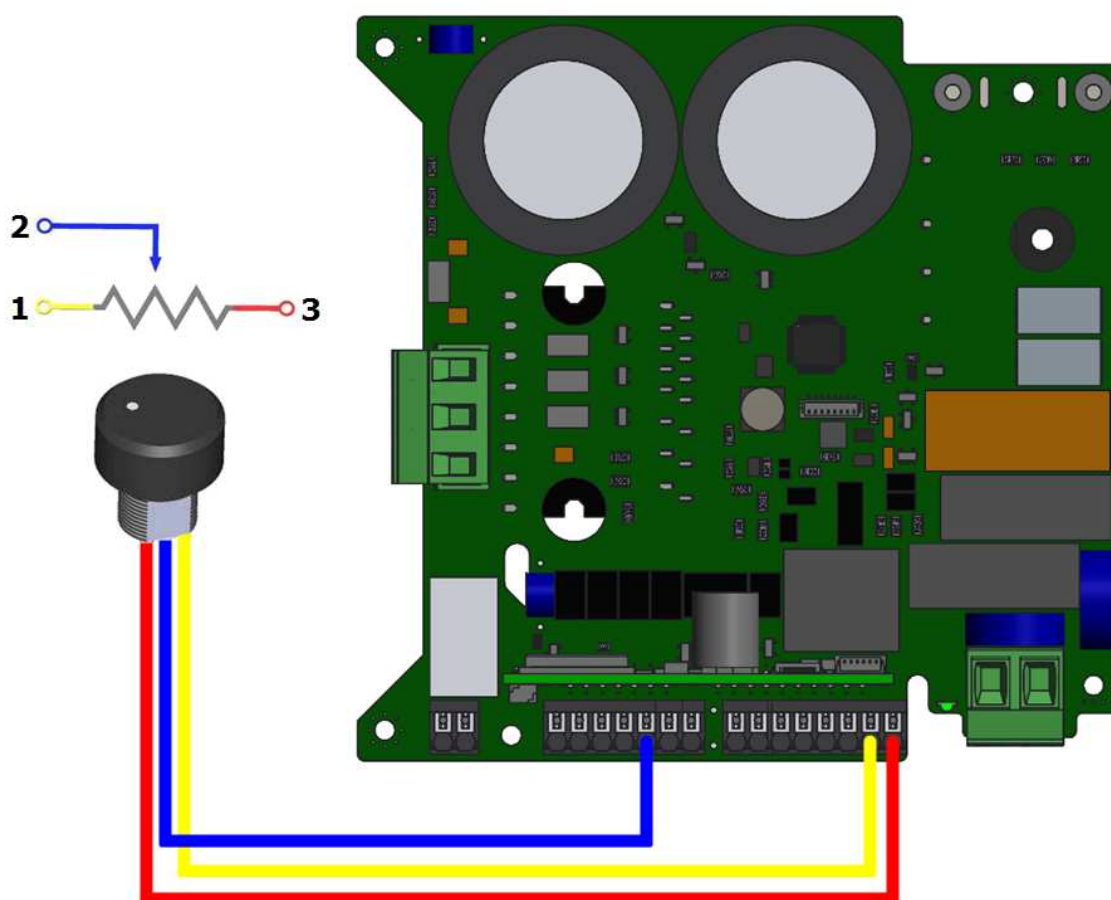

- Connection of a pressure transducer (Fig. COM3).
 Connect transducer supply wire to the 12Vdc terminal and transducer signal wire to an available Analog Input (for example AI0).
 Program the Analog Input as follows:
 Analog Input AI0 → PID feedback.
 Parameter 51 “Analog Input 0 function setup” → PID feedback;
 Parameter 26 “Input Signal” → 1 (=Analog input);
 Then set the type of signal provided by the pressure transducer (0-10V or 4-20mA) at parameter 27 “Analog Input 0 Setup”.

NOTE: The minimum transducer power supply voltage to be connected to the inverter must not be higher than 12Vdc.
 All the transducers that must be supplied by 0Vdc are not compatible with the inverter.

Fig. COM3

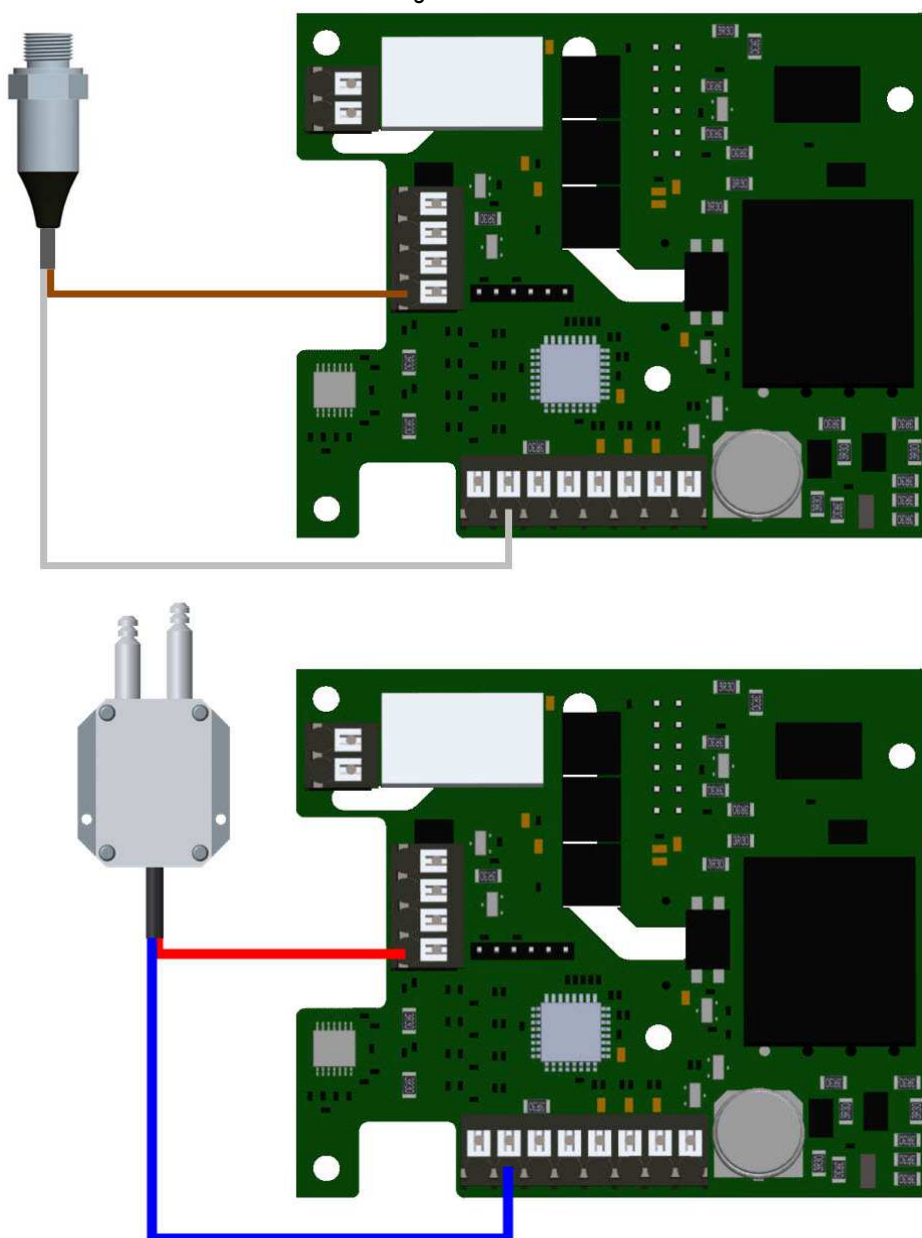

- Connection of a pressure transducer (Fig. COM3).
 Connect transducer supply wire to the 10Vdc terminal and transducer signal wire to an available Analog Input (for example AI0).
 Program the Analog Input as follows:
 Analog Input AI0 → PID feedback.
 Parameter 51 “Analog Input 0 function setup” → PID feedback;
 Parameter 26 “Input Signal” → 1 (=Analog input);
 Then set the type of signal provided by the pressure transducer (0-10V or 4-20mA) at parameter 27 “Analog Input 0 Setup”.
 NOTE: The minimum transducer power supply voltage to be connected to the inverter must not be higher than 24Vdc.
 All the transducers that must be supplied by 0Vdc are not compatible with the inverter.

Fig. COM3

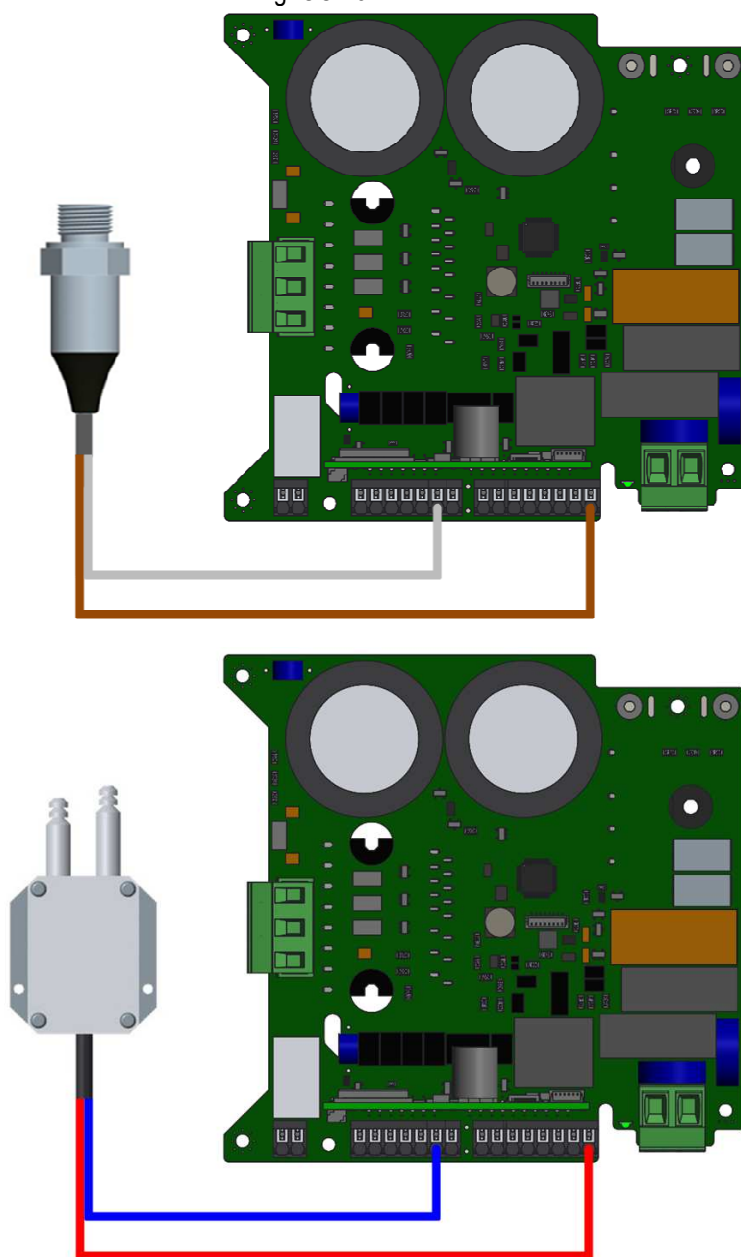

- If it is necessary to connect an external enabling contact (Fig. COM4), it must be connected between the 12Vdc terminal and an available Digital Input (for example DI2) that will be programmed as follows:
Parameter 45 "Digital Input 2 function setup" → Brake.

This function can also be used as an emergency stop: when the contact on the input is closed, the motor is stopped in the braking times set at the reference parameter 34.

Fig. COM4

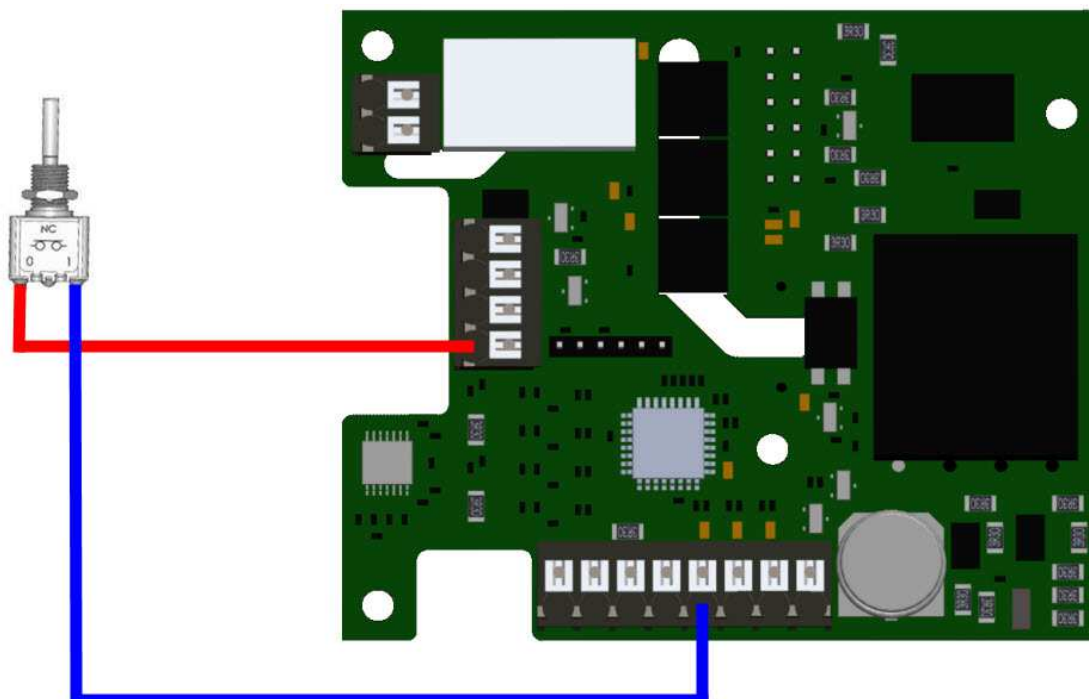

- If it is necessary to connect an external enabling contact (Fig. COM4), it must be connected between the 0Vdc terminal and an available Digital Input (for example DI2) that will be programmed as follows:
Parameter 45 “Digital Input 2 function setup” → Brake.

This function can also be used as an emergency stop: when the contact on the input is closed, the motor is stopped in the braking times set at the reference parameter 34.

Fig. COM4

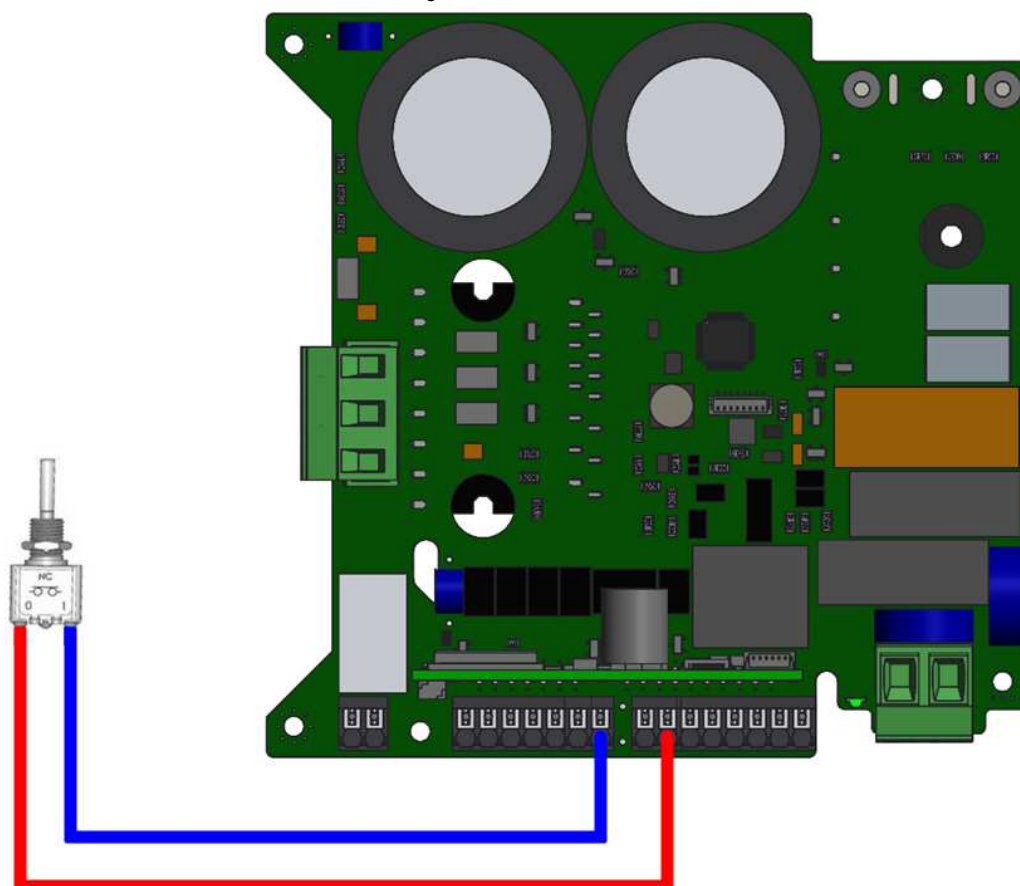

- If it is necessary to connect an external enabling contact (Fig. COM4), it must be connected between the 24Vdc terminal and Enable Input.

This function can also be used as an emergency stop: when the contact on the Enable input is open, the motor is stopped and the inverter is totally disabled until the contact returns closed.

Fig. COM4

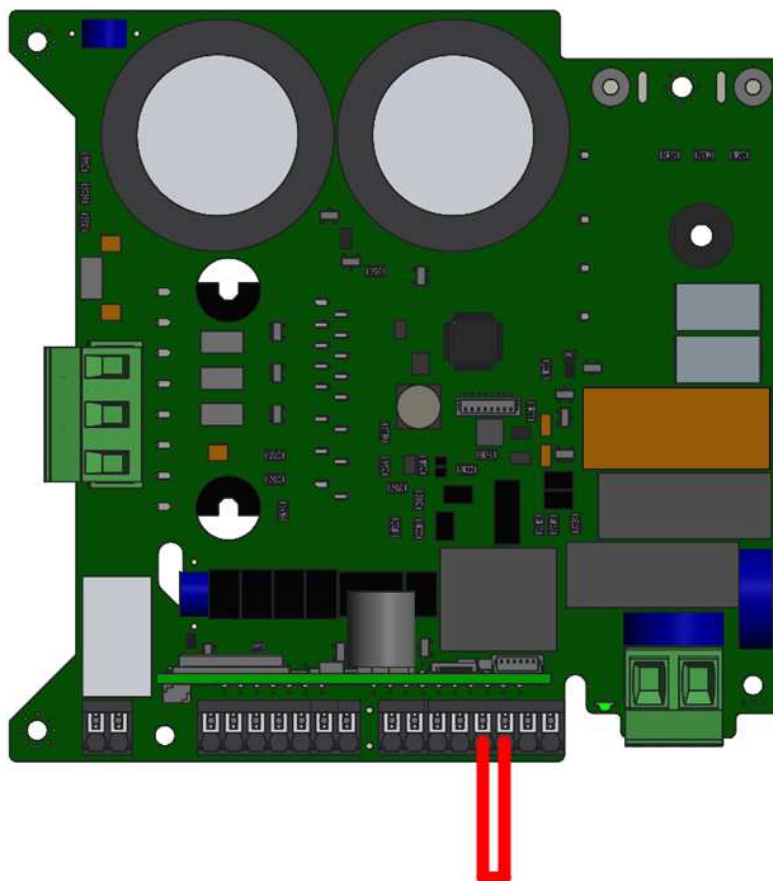

- Connection Bluetooth module for smartphone and tablet control (optional code BLUE).
Program the Modbus communication as follows:
Parameter 40 "Modbus communication" → 2 (=Program and control only from Modbus).

Then connect BLUE to NANO (Fig. COM4):
red wire to the 12Vdc terminal on the I/O Module;
black wire to the 0Vdc terminal on the I/O Module;
white wire to the A+ terminal on the Power Module;
green wire to the B- terminal on the Power Module.

Fig. COM5 (1^version)

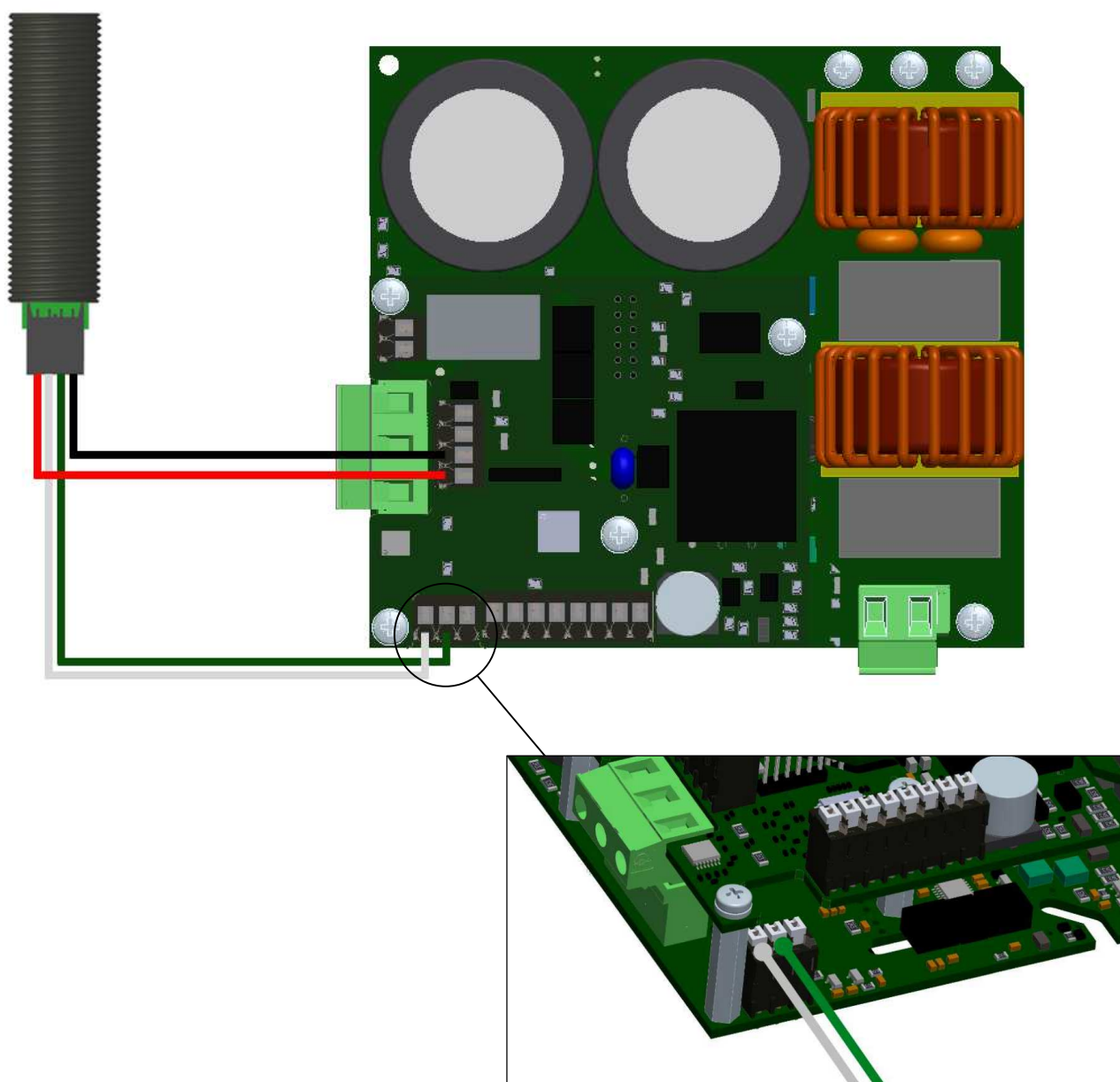

- Connection Bluetooth module for smartphone and tablet control (optional code BLUE).
Program the Modbus communication as follows:
Parameter 40 "Modbus communication" → 2 (=Program and control only from Modbus).

Then connect BLUE to NANO (Fig. COM4):
red wire to the 24Vdc terminal;
black wire to the 0Vdc terminal;
white wire to the RS485 A+ terminal;
green wire to the RS485 B- terminal.

Fig. COM5 (2[^]version)

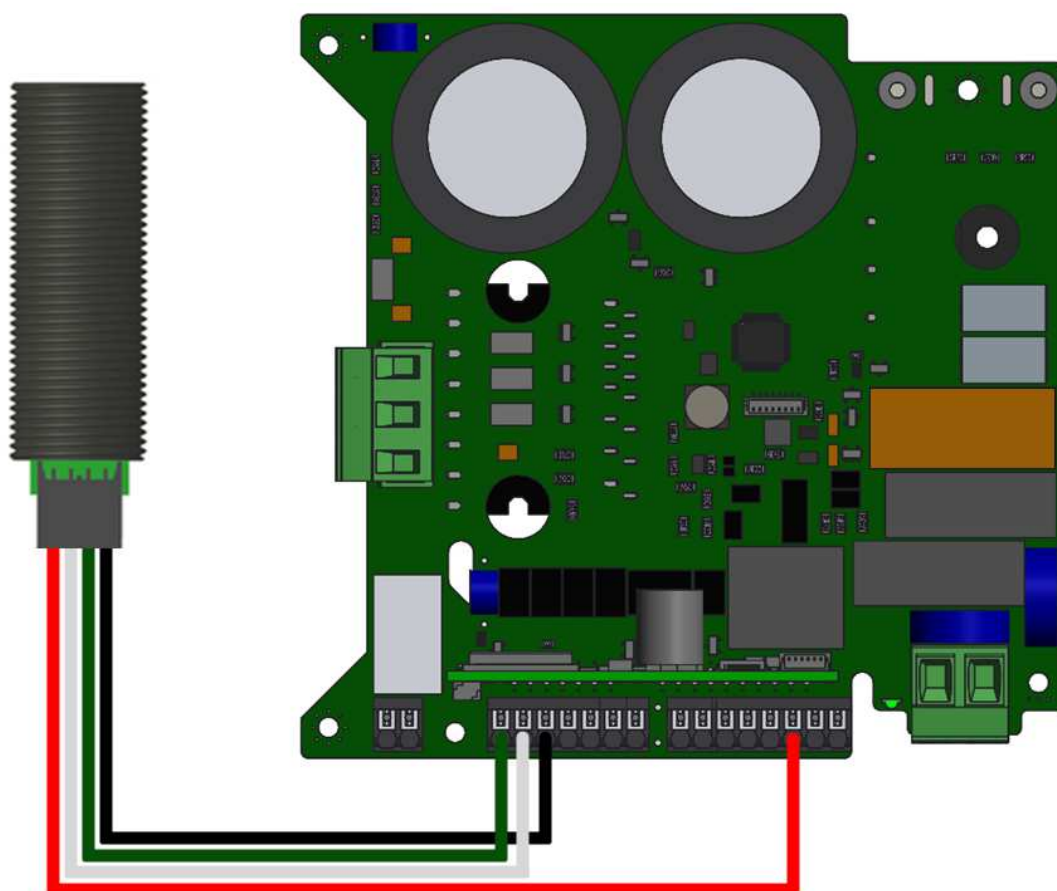

- Connection and control of the electromagnetic brake (Fig. COM6).
 Program the digital output DO0 as follows:
 Parameter 47 "Digital output 0 setup" → 1 (=Motor run).

Then make the following connections:

neutral external 230Vac power supply to "AC" terminal of the rectifier;
 phase external 230Vac power supply to terminal 1 of the digital output DO0;
 terminal 2 of the digital output DO0 to "AC" terminal of the rectifier;
 "+DC" and "-DC" terminals of the rectifier to the electromagnetic brake.

Fig. COM6 (1^version)

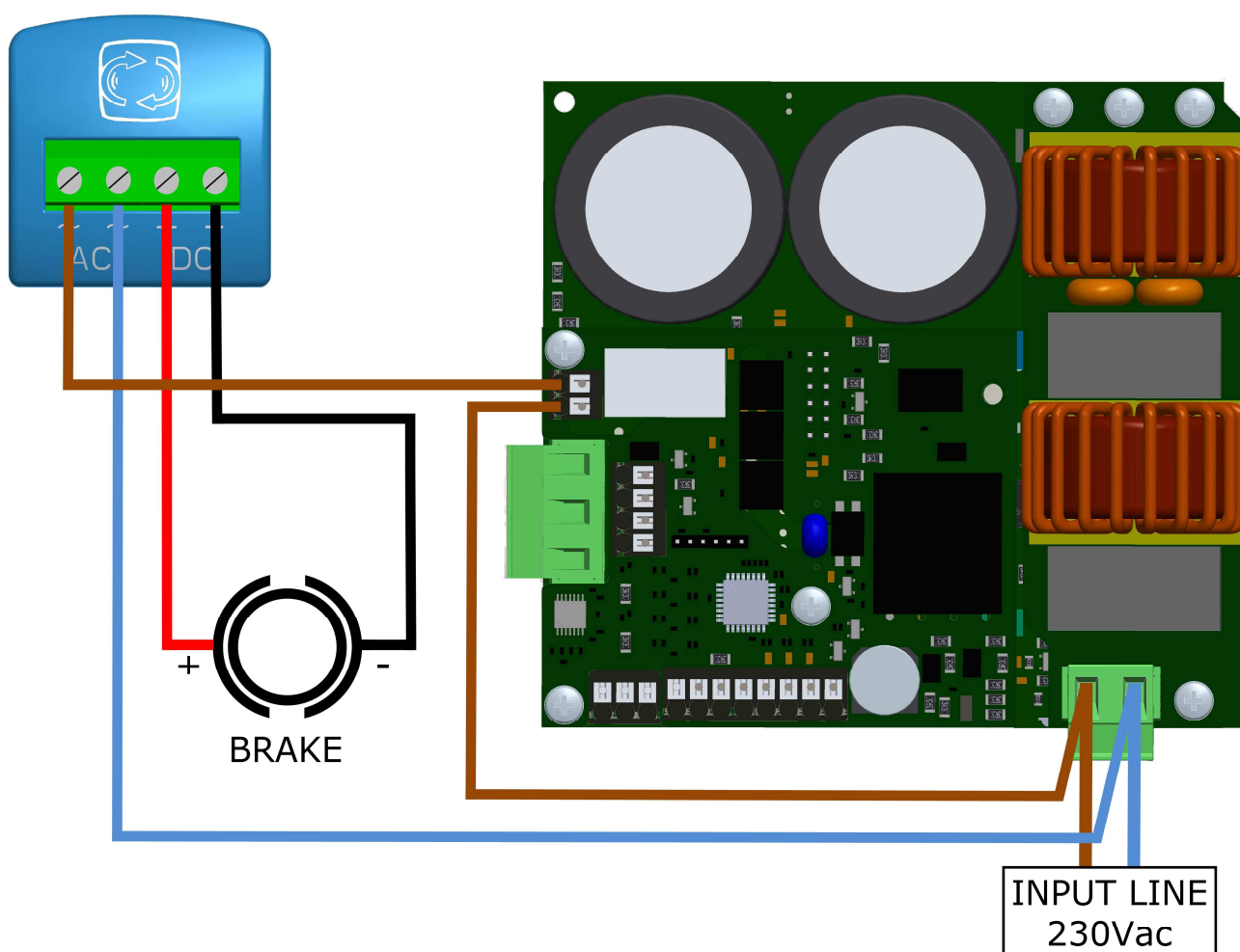

- Connection and control of the electromagnetic brake (Fig. COM6).
 Program the digital output DO0 as follows:
 Parameter 47 "Digital output 0 setup" → 1 (=Motor run).

Then make the following connections:

neutral external 230Vac power supply to "AC" terminal of the rectifier;
 phase external 230Vac power supply to terminal 1 of the digital output DO0;
 terminal 2 of the digital output DO0 to "AC" terminal of the rectifier;
 "+DC" and "-DC" terminals of the rectifier to the electromagnetic brake.

Fig. COM6 (2[^]version)

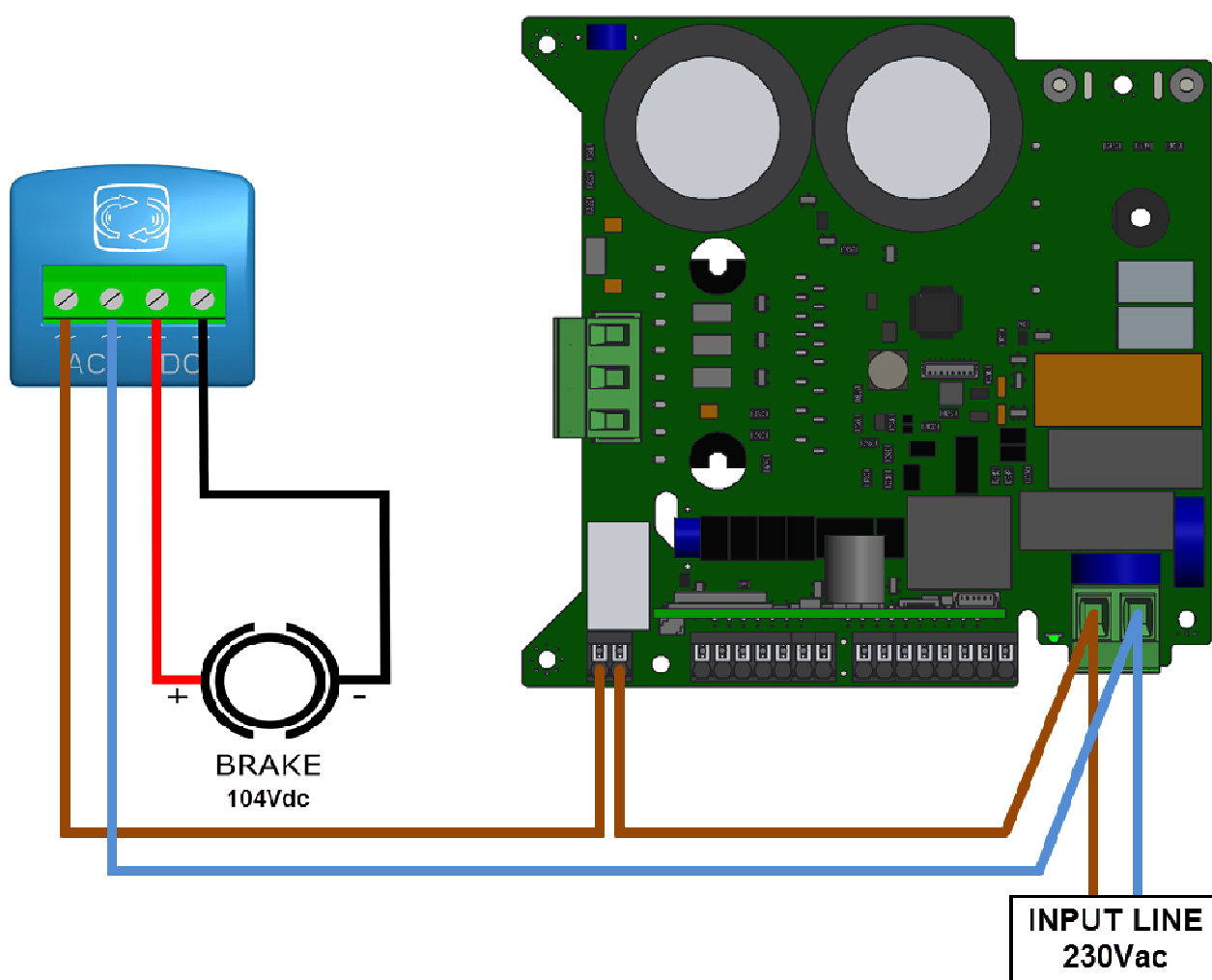

5d.2 Bluetooth module mounting (optional code BLUE)

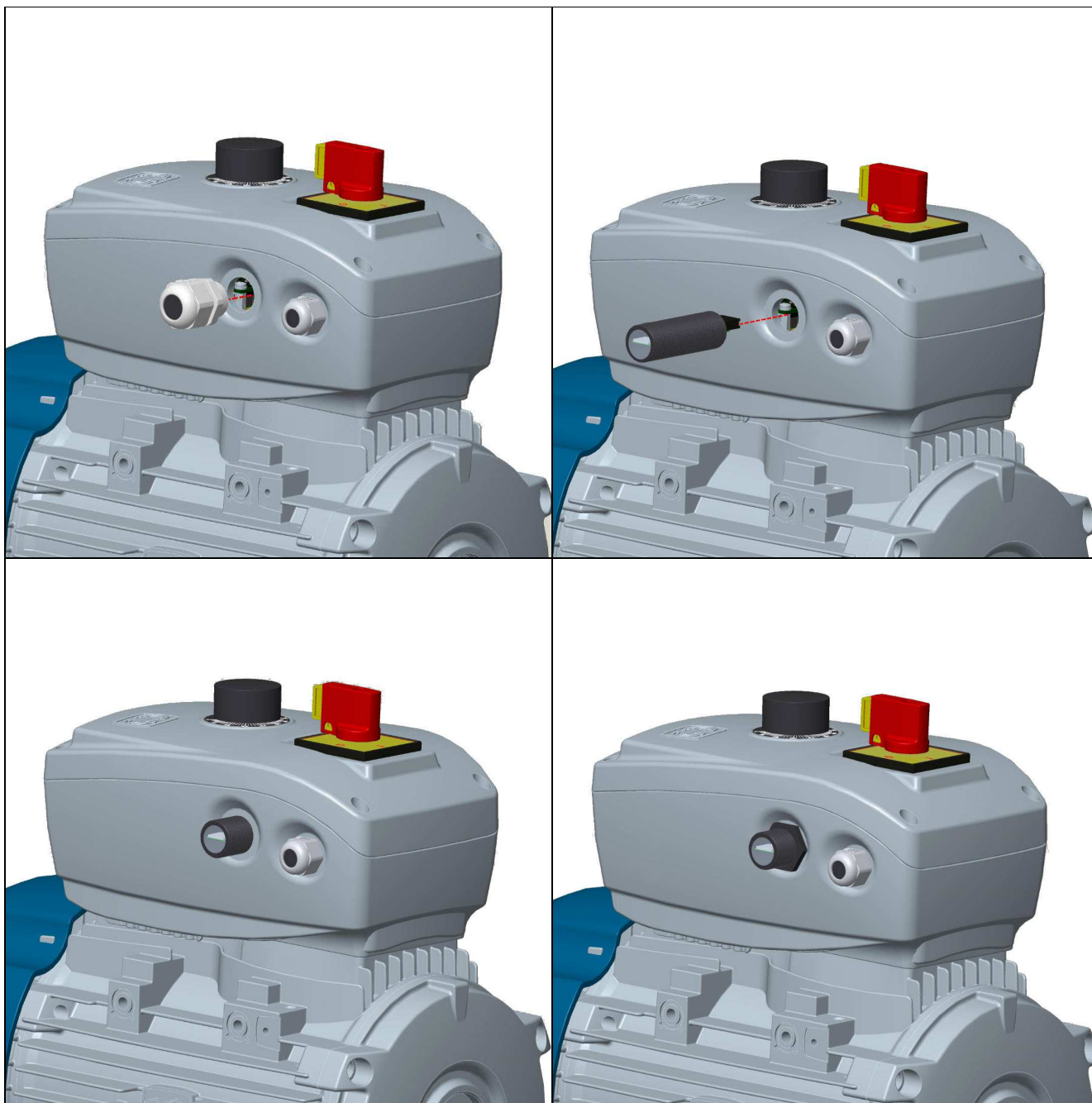

5d.3 Power Switch mounting (optional code ITEM1X12A)

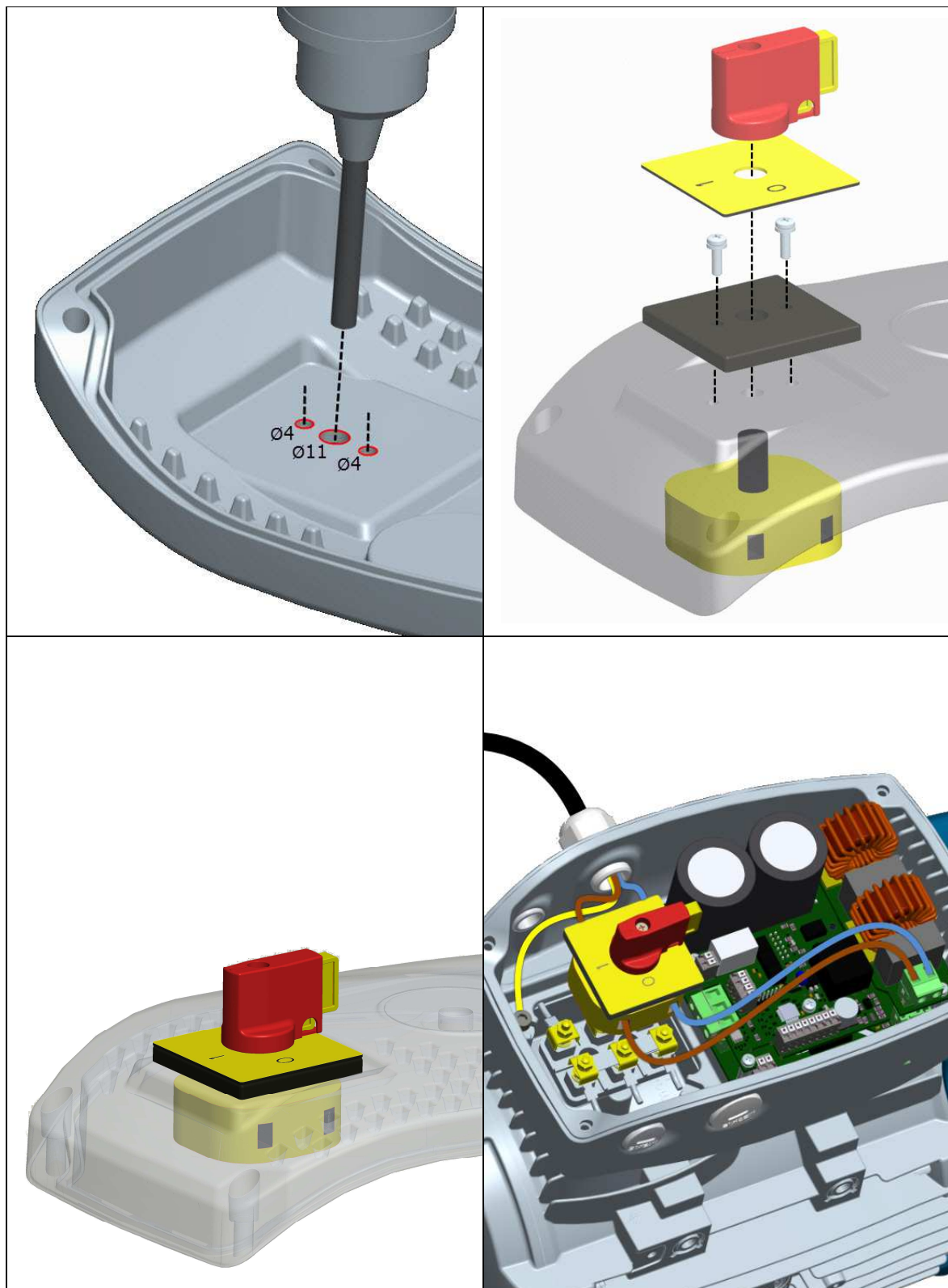

5d.4 Potentiometer mounting (optional code NANPOT)

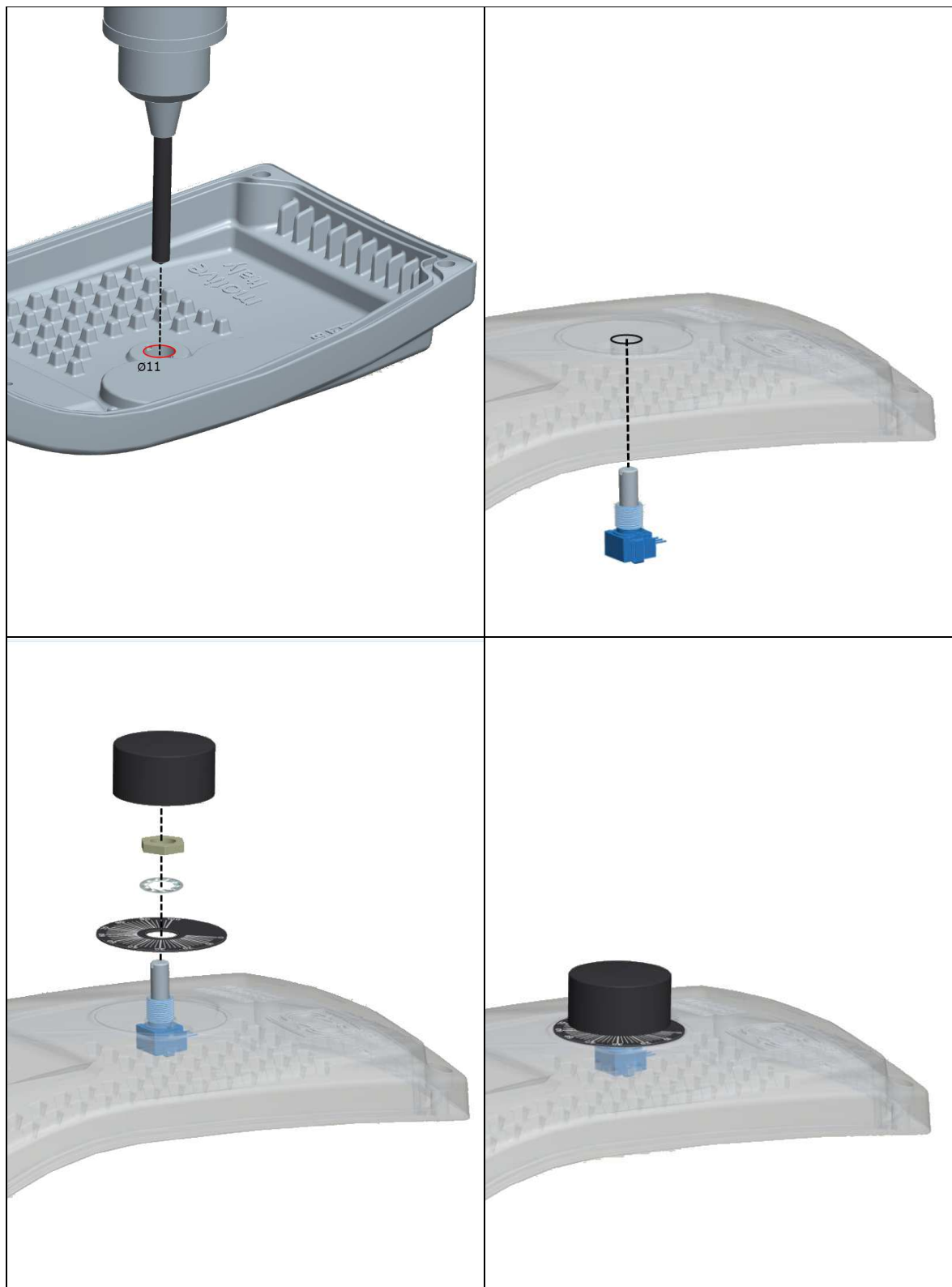

6. FUNCTIONS

6a. Main characteristics

Section	Characteristic	Range
Motore	Rated Power at 230Vac [kW]	0.13 ÷ 1.1 (NANO-1,1); 0.13 ÷ 2.2 (NANO-2,2)
	Rated Voltage [V]	with input 110Vac single phase: 90 ÷ 110Vac three phase with input 230Vac single phase: 90 ÷ 230Vac three phase
	Rated Current [A]	0.1 ÷ 5 (NANO-1,1); 0.1 ÷ 10 (NANO-2,2)
	Rated frequency [Hz]	50 / 60
	Rated RPM	350 ÷ 5950
Motor limits	Maximum speed [% di rpm]	2 ÷ 200
	Minimum speed [% di rpm]	0 ÷ 120
	Acceleration [sec]	0.1 ÷ 99
	Deceleration [sec]	0.1 ÷ 99
	Maximum inrush current [% of rated current]	80 ÷ 200
	Magnetization [%]	70 ÷ 120 The magnetizing current of the motor, is that which does not determine active power absorption (W) but only reactive (VAR). It is not a booster, as this magnetizing current is maintained even after the starting phase. Increasing this %, at the same frequency, you increase the Volts to the motor (up to the max value of the power net voltage minus the circuit falls), thus increasing the magnetic flux in the motor. This raises the no-load current and enhances the torque up to the motor saturation. In case of electric vibration of the motor, you can make it disappear by reducing this % value. Do it at 2% steps till you get the required result.
Braking voltage [V]	0 ÷ 200 Electronic control that allows the motor inertia to be braked quickly by a DC voltage injection into the windings. The duration of the braking is adjustable from 1msec to 60sec.	
Boost voltage [V]	0 ÷ 50 Command that allows increasing the motor torque at low speeds through an additional voltage.	
Control	Start/Stop command	<ul style="list-style-type: none"> · from controls wired to the I/O Module · from modbus through the Power Module
	Input reference	<ul style="list-style-type: none"> · internal (modbus parameter 19) · modbus (modbus parameter 106) · analogic signal 0-10V (I/O Module) · analogic signal 4-20mA (I/O Module)
	Mode	<ul style="list-style-type: none"> · Open loop speed · Ventilation · Air compressor · Oleodynamic pump

Feedback (only for Ventilation, Air Compressor, Oleodynamic pump)	Transducer range	0 ÷ 16000 (Bar, Psi, Pascal)
	Pressure reference	0 ÷ 16000 (Bar, Psi, Pascal)
	Pressure hysteresis	1 ÷ 16000 (Bar, Psi, Pascal)
P.I.D. Factors	K Proportional Factor	1 ÷ 100 Multiply the error of the reference
	K Integral Factor	1 ÷ 100 Multiplies the integral of the error
RS485 Modbus	Communication	ON= Program and control only from modbus ON+KEY= Control from the I/O Module, reference value from modbus OFF= Control only from the I/O Module
	Baude Rate [bit/sec]	4800, 9600, 14400, 19200. Means the speed at which bits are transmitted. The BaudRate is expressed in bits per second. Start Bit, Data Bit, Parity Bit (if used) and Stop Bit are included. However, only data bits are saved.
	Modbus address	1 ÷ 127

6b. Alarms

The alarm signal is reported by a red flashing sequence of the status LED on the side of the inverter.



			Flashing code
1	Current peak	Immediate intervention for overcurrent.	●●●●●●●● Short and consecutive flashes
2	DC-Bus overvoltage	Overvoltage due to the generator functioning during deceleration or undervoltage.	● One short flash
3	Inverter temperature	Exceeding the temperature limit on the electronic board (91°C).	●● Two short flashes
4	DC-Bus undervoltage	Voltage value insufficient to keep the motor running at a given load.	●●● Three short flashes
5	Short circuit	Immediate intervention for short circuit.	●● One short and one long flash
6	Module fault	Fault or anomaly on the inverter power module.	●●● Two short and one long flash
7	Parameter error	Error in writing one or more parameters.	●●●● Three short and one long flash
8	Expansion board communication error	Fault or anomaly on the inverter I/O expansion module.	● One long flash
9	Maximum pressure limitation alarm	Maximum limit pressure reached at parameter 66 "Maximum pressure limitation".	●●●●● Four short and one long flash

The restart after alarm must be preceded by a verification of the system, in order to find the reason of the alarm. Unconditioned restarts can lead to the product destruction and to a risk for the safety of the connected machines and the users.

The alarm can be reset automatically by enabling parameter 23 "Enable Restart", or by restarting the inverter. If the alarm persists, please contact Motive technical assistance.



6c. Modbus

Modbus must be connected to the inverter through the RS485 serial on the power module:

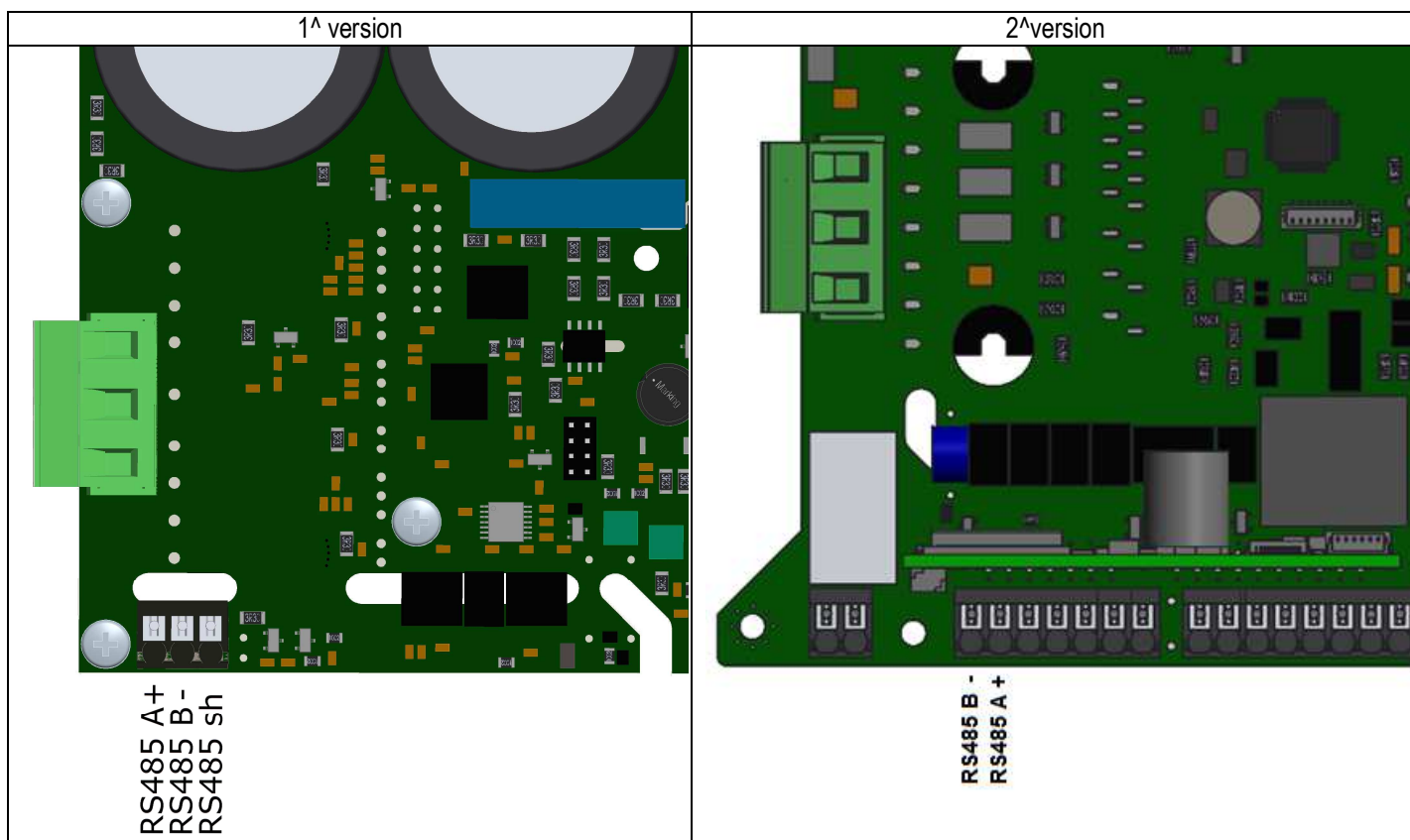

Modbus communication can be controlled by:

A. Smartphone/tablet



Only for smartphone and tablet



It's necessary to connect the Motive bluetooth

device BLUE

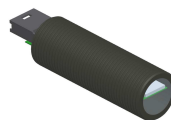

to NANO modbus terminals



1. Go to "App Store" or "Play Store"
2. Type "Motive Inverter NANO"





3. Click on "Inverter NANO" icon
4. Start to use

Motive NANO APP is automatically in Italian or English (for all non-Italian users) depending by the settings of your smartphone or tablet.

Now it's possible to set up Modbus communication (Section 4), program (Section 3), manually control (Section 2), monitor operations (section 1).

Nano Inverter

1- Monitor section

Speed [rpm] **1706**

Current [A] **2.4**

Rotation direction

STOP
 ON CW
 ON CCW

Inverter status

POWER
 MOTOR
 ALARM
 FAN

81	Power output [W]	R	448
83	Output voltage [V]	R	135
87	Output frequency [Hz]	R	28.4
84	Power module temperature [°C]	R	15
85	DC Bus voltage [Vdc]	R	312
89	Recorded alarm	R	4

Nano Inverter

2- Commands section

Rotation



106	Speed [RPM]	R/W	900
109	Acceleration [seconds]	R/W	15
110	Deceleration [seconds]	R/W	15

Nano Inverter

3- Parameters section

Motor data			
6	Rated power [kW]	R/W	2.2
7	Rated voltage [V]	R/W	230
8	Rated current [A]	R/W	8
9	Rated frequency [Hz]	R/W	50
10	Rated RPM [rpm]	R/W	2891
11	Sliding compensation filter [ms]	R/W	700
38	Magnetization [%]	R/W	100
Application data			
12	Sliding maximum torque [%]	R/W	5
13	Maximum speed [% of motor synchronous speed]	R/W	100
14	Minimum speed [% of motor synchronous speed]	R/W	0
15	Acceleration [seconds]	R/W	15
16	Deceleration [seconds]	R/W	15
17	Maximum inrush current [%in]	R/W	100
18	Rotation direction	R/W	1
19	Internal speed [rpm]	R/W	900
21	Boost voltage [V]	R/W	0
23	Enable automatic restart	R/W	1
24	Dead time after alarm [seconds]	R/W	5
30	Proportional factor	R/W	8000
31	Integral factor	R/W	0
33	Voltage feed of the brake coil [V]	R/W	20
34	Brake time [ms]	R/W	5000

Nano Inverter

3- Parameters section

Commands origin	
Digital input 0 function	
<input type="radio"/>	No function
<input checked="" type="radio"/>	Motor clockwise start/stop
<input type="radio"/>	Motor start/brake
<input type="radio"/>	Reverse
<input type="radio"/>	Brake
<input type="radio"/>	Motor counterclockwise start/stop
Digital input 1 function	
<input checked="" type="radio"/>	No function
<input type="radio"/>	Motor clockwise start/stop
<input type="radio"/>	Motor start/brake
<input type="radio"/>	Reverse
<input type="radio"/>	Brake
<input type="radio"/>	Motor counterclockwise start/stop
Digital input 2 function	
<input checked="" type="radio"/>	No function
<input type="radio"/>	Motor clockwise start/stop
<input type="radio"/>	Motor start/brake
<input type="radio"/>	Reverse
<input type="radio"/>	Brake
<input type="radio"/>	Motor counterclockwise start/stop
Digital output 0 function	
<input checked="" type="radio"/>	No function
<input type="radio"/>	Moving motor
<input type="radio"/>	Rotation direction
<input type="radio"/>	End of ramp speed reached
<input type="radio"/>	Fault
<input type="radio"/>	Stopped motor
<input type="radio"/>	Compressor valve

Nano Inverter

3- Parameters section

Speed signal origin	
<input checked="" type="radio"/>	Internal reference
<input type="radio"/>	Analog input
Analog input 0 function	
<input checked="" type="radio"/>	No function
<input type="radio"/>	Potentiometer speed reference
<input type="radio"/>	Speed reference
<input type="radio"/>	Current limit
<input type="radio"/>	PID input
Analog input 0 signal	
<input type="radio"/>	0-10V
<input checked="" type="radio"/>	4-20mA
Analog input 1 function	
<input type="radio"/>	No function
<input type="radio"/>	Potentiometer speed reference
<input type="radio"/>	Speed reference
<input type="radio"/>	Current limit
<input checked="" type="radio"/>	PID input
Analog input 1 signal	
<input type="radio"/>	0-10V
<input checked="" type="radio"/>	4-20mA
Analog output 0 function	
<input checked="" type="radio"/>	No function
<input type="radio"/>	Motor speed (0-12V)
<input type="radio"/>	Current absorption (0-12V)

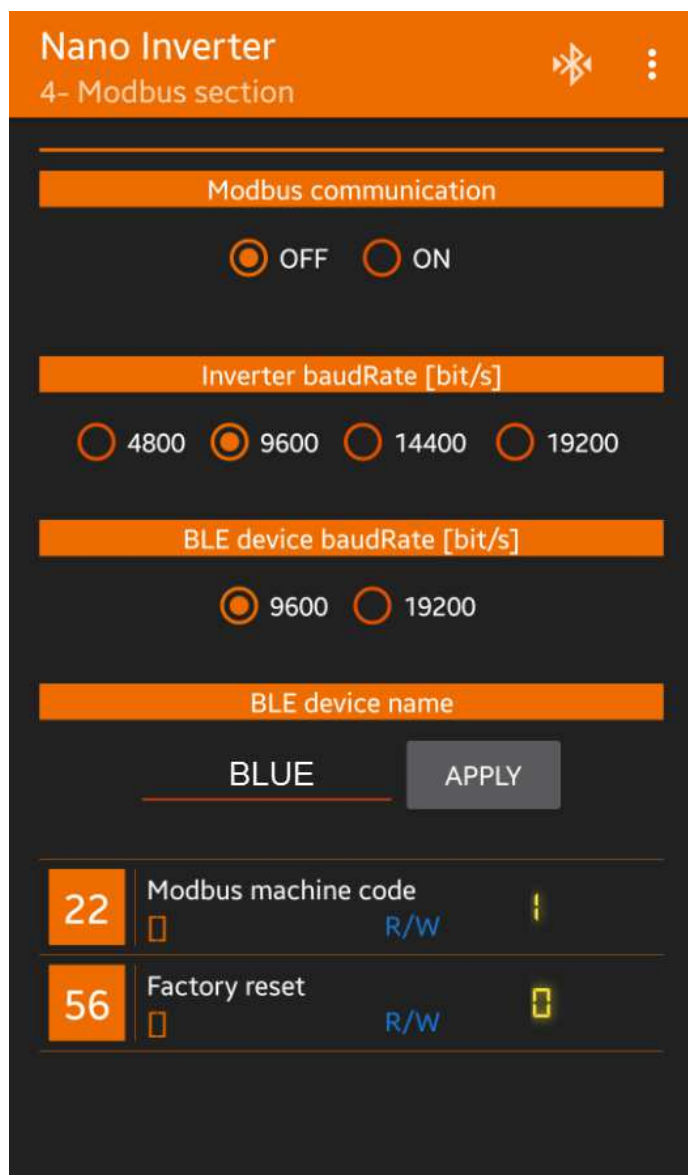

B. PLC, using parameters reported in “NANO Modbus Parameters” chart.



C. PC, downloading the "Motive Motor Manager" (Chapter 7) interface with Motive USB-RS485 converter:

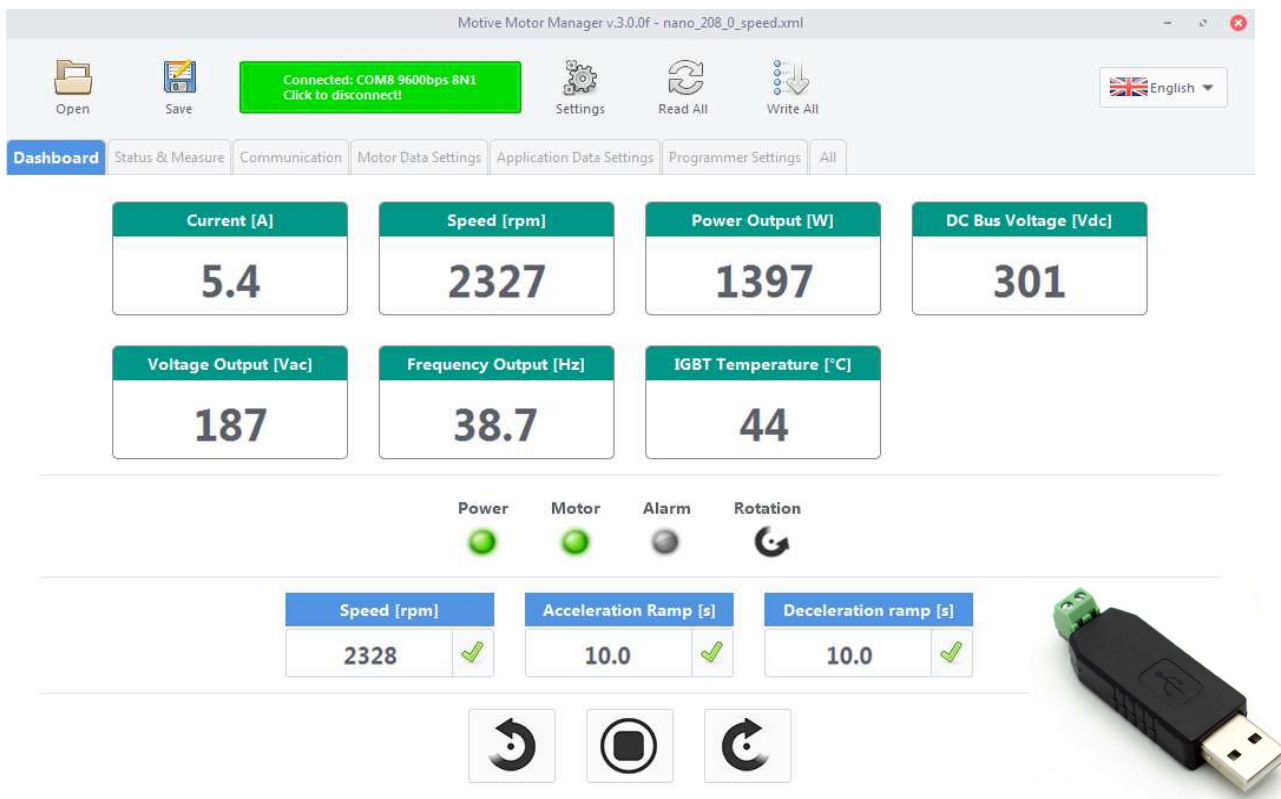

Connection USB-RS485 converter to the inverter (do this operation with not powered inverter!):

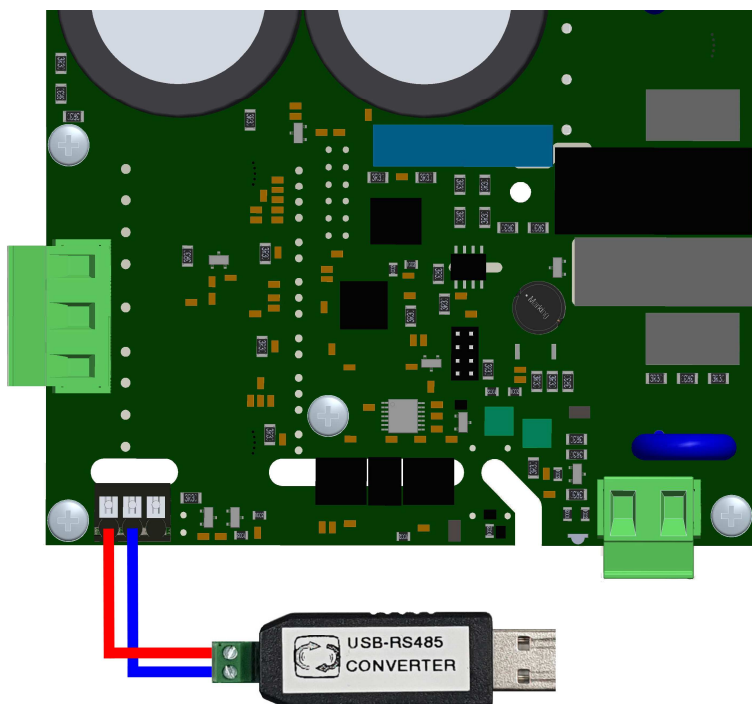

USB-RS485 converter is automatically installed on PC. If this doesn't happen, download the driver at the following link:
https://www.motive.it/upload/documenti/software/USB-RS485_Driver.zip

Connection USB-RS485 converter to the inverter (do this operation with not powered inverter!):

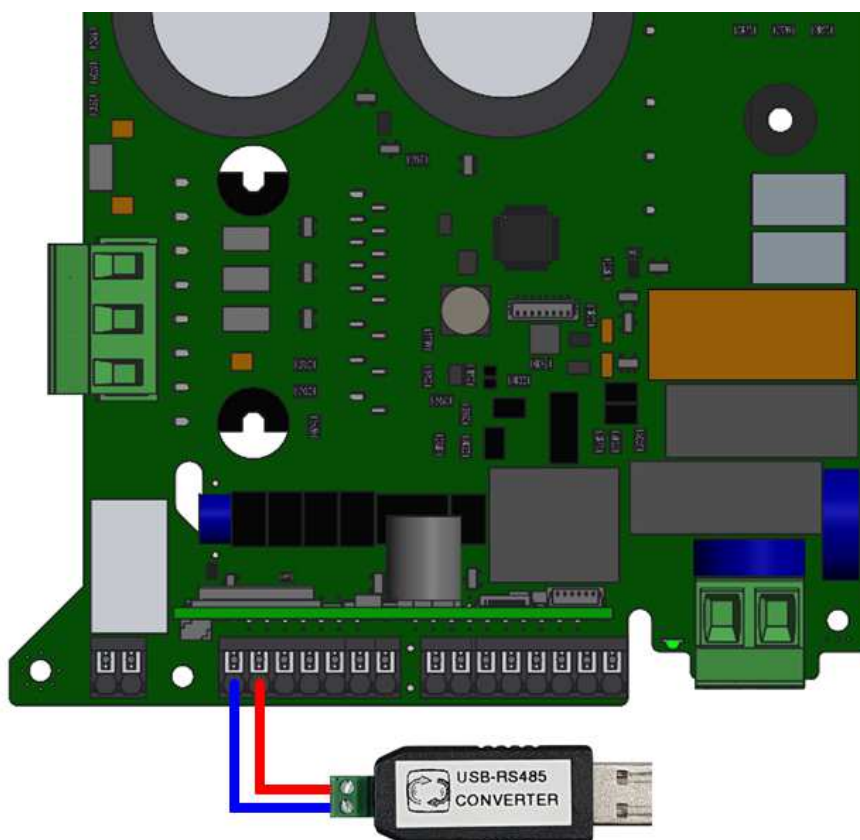

USB-RS485 converter is automatically installed on PC. If this doesn't happen, download the driver at the following link:
https://www.motive.it/upload/documenti/software/USB-RS485_Driver.zip

7. MOTIVE MOTOR MANAGER

7a. Download and installation



Download PC interface “Motive Motor Manager” at following link:

<https://www.motive.it/upload/documenti/software/MotiveMotorManager.zip>

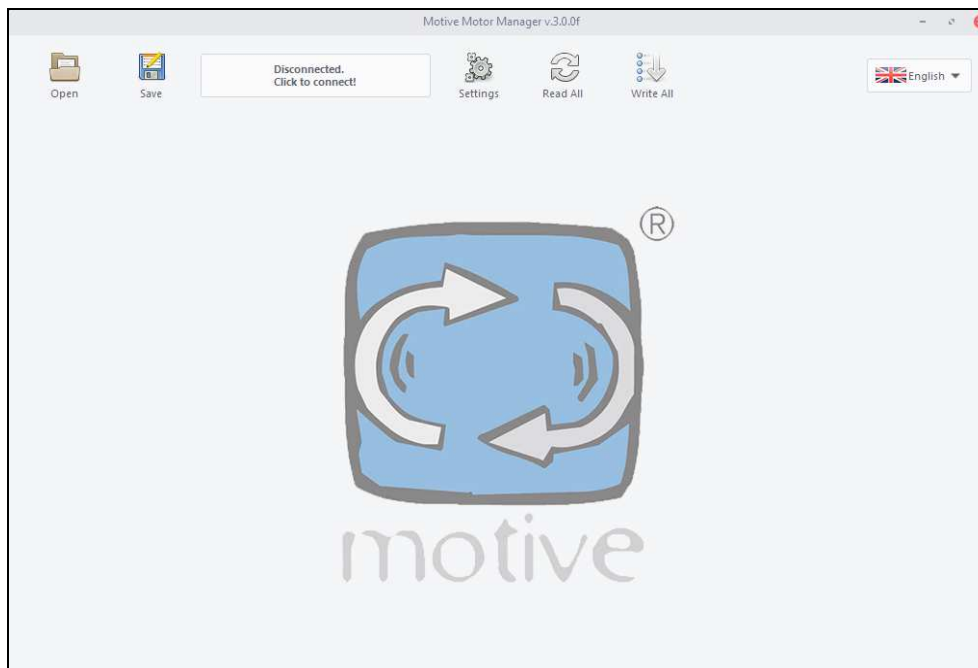

System requirements:

Windows 7-8-10, Windows Server 2003-2008-2016

USB port

NET Framework 3.5 or next

Software installation:

Download the SW. Save the zip file on the desktop

Please install the program using the executable file “installer.exe”. To run the program is recommended to log as administrator.

Please follow the instructions till the end of this procedure.

At the end of the installation you will find a new icon  on your desktop.

Click on the icon to run the program.

Switch on the inverter.

Choose the language in the drop-down menu at the top right.



7b. USB-RS485 Converter connection settings

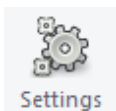

Click on the icon **Settings** to set the correct USB port to which the inverter is connected. At the end, click “Apply”.

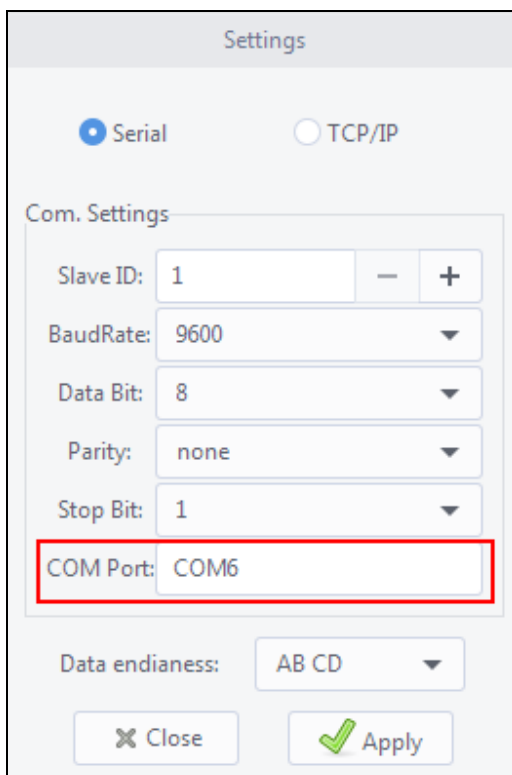

The image shows a 'Settings' dialog box with two radio buttons: 'Serial' (selected) and 'TCP/IP'. Under 'Com. Settings', there are several fields: 'Slave ID' (1), 'BaudRate' (9600), 'Data Bit' (8), 'Parity' (none), and 'Stop Bit' (1). The 'COM Port' field is highlighted with a red box and contains 'COM6'. Below these fields is a 'Data endianness' dropdown set to 'AB CD'. At the bottom are 'Close' and 'Apply' buttons.

Then click on “Click to connect!” to communicate with NANO.

If the USB port has been correctly set, the bar will turn green (the device is connected to the PC).

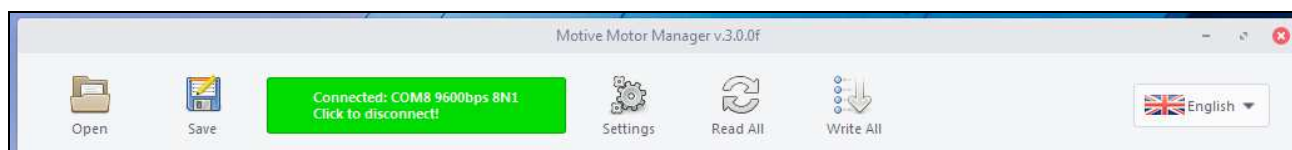

If not, the bar will turn red (the device is not connected to the PC).

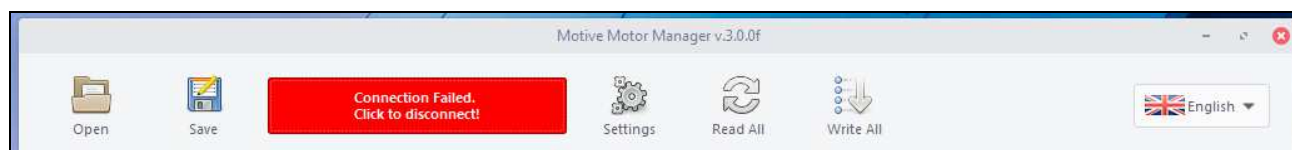

Once the device is connected to the PC, Motive Motor Manager recognizes the inverter and automatically loads the default parameter list.

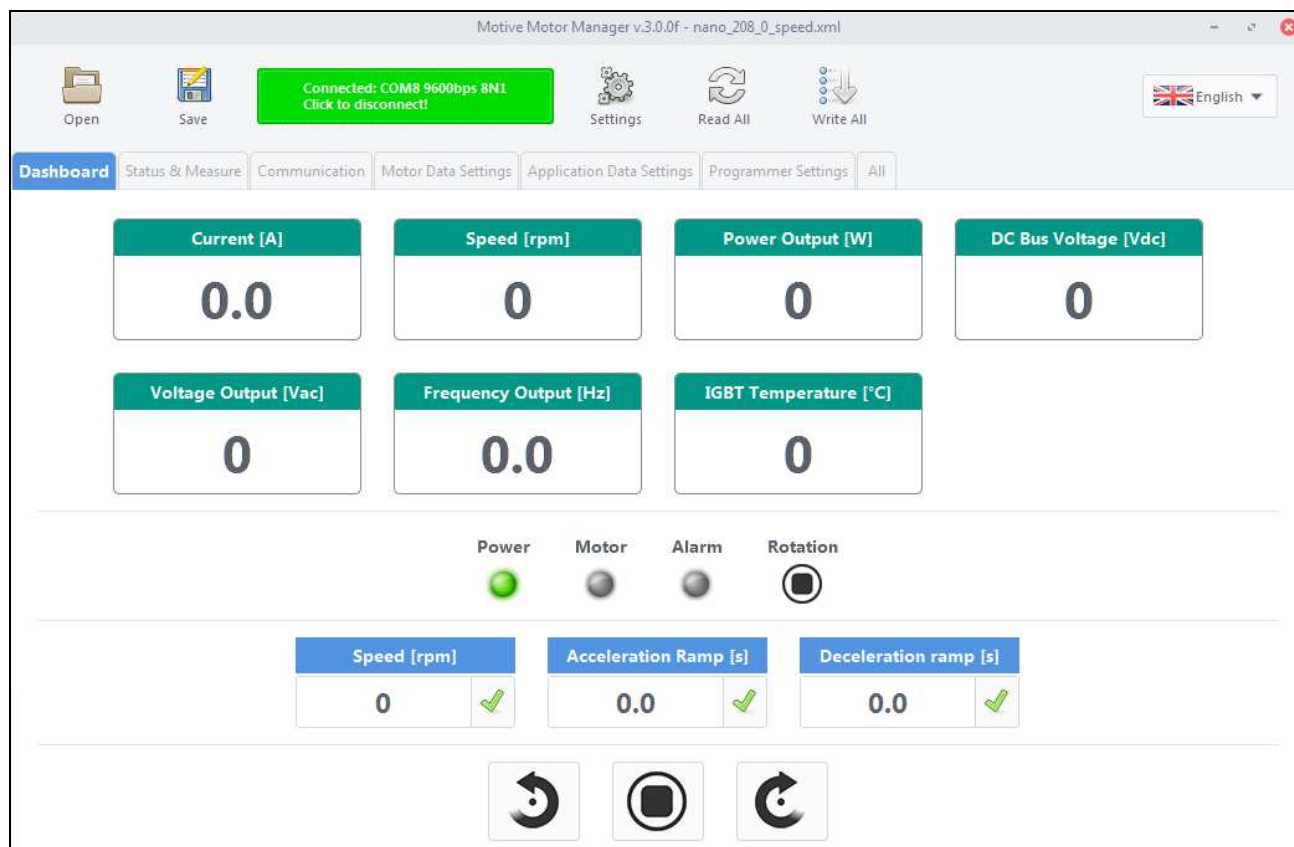

7c. Main functions

The program consists of 6 sheets:

- **Dashboard**, where you can control the main measured values, change the speed, the rotation and start/stop the motor manually;

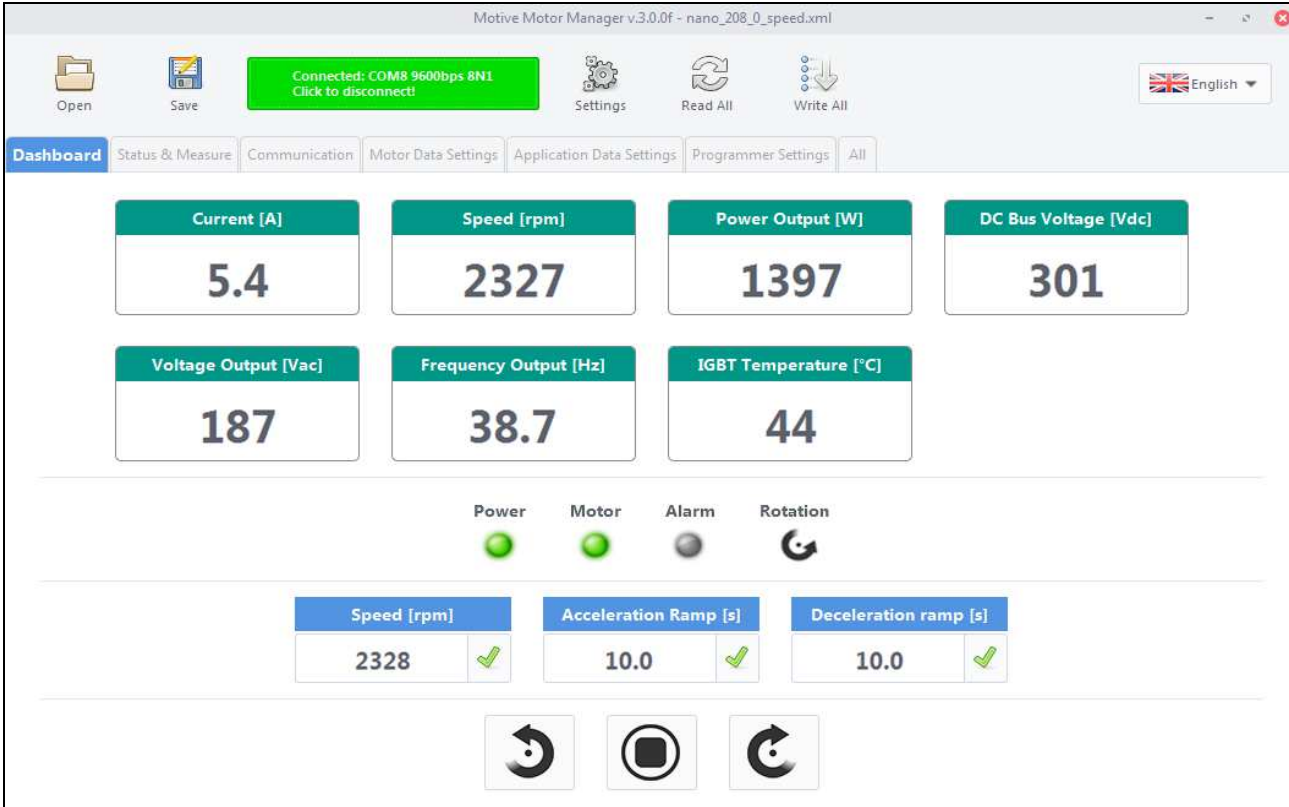

- **Status&Measure**, where you can see all the measured values;

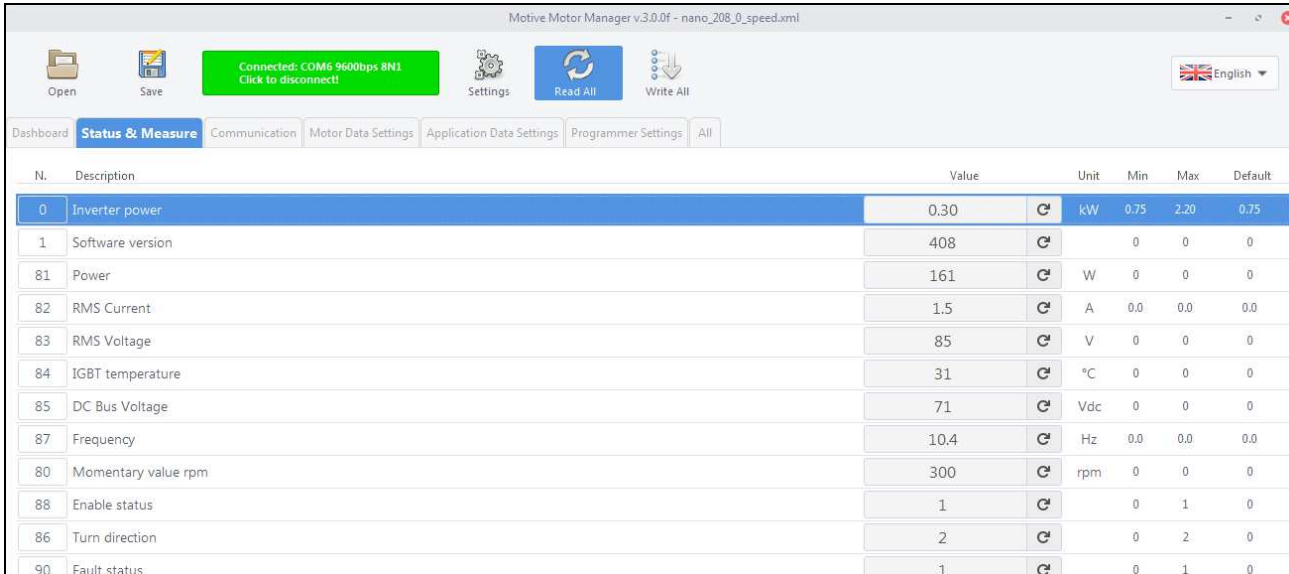

N.	Description	Value	Unit	Min	Max	Default
0	Inverter power	0.30	kW	0.75	2.20	0.75
1	Software version	408		0	0	0
81	Power	161	W	0	0	0
82	RMS Current	1.5	A	0.0	0.0	0.0
83	RMS Voltage	85	V	0	0	0
84	IGBT temperature	31	°C	0	0	0
85	DC Bus Voltage	71	Vdc	0	0	0
87	Frequency	10.4	Hz	0.0	0.0	0.0
80	Momentary value rpm	300	rpm	0	0	0
88	Enable status	1		0	1	0
86	Turn direction	2		0	2	0
90	Fault status	1		0	1	0

- **Communication**, where you can enable/disable the Modbus communication and control (for programming and controlling inverter by Modbus, set parameter 40 "Modbus communication" =2);

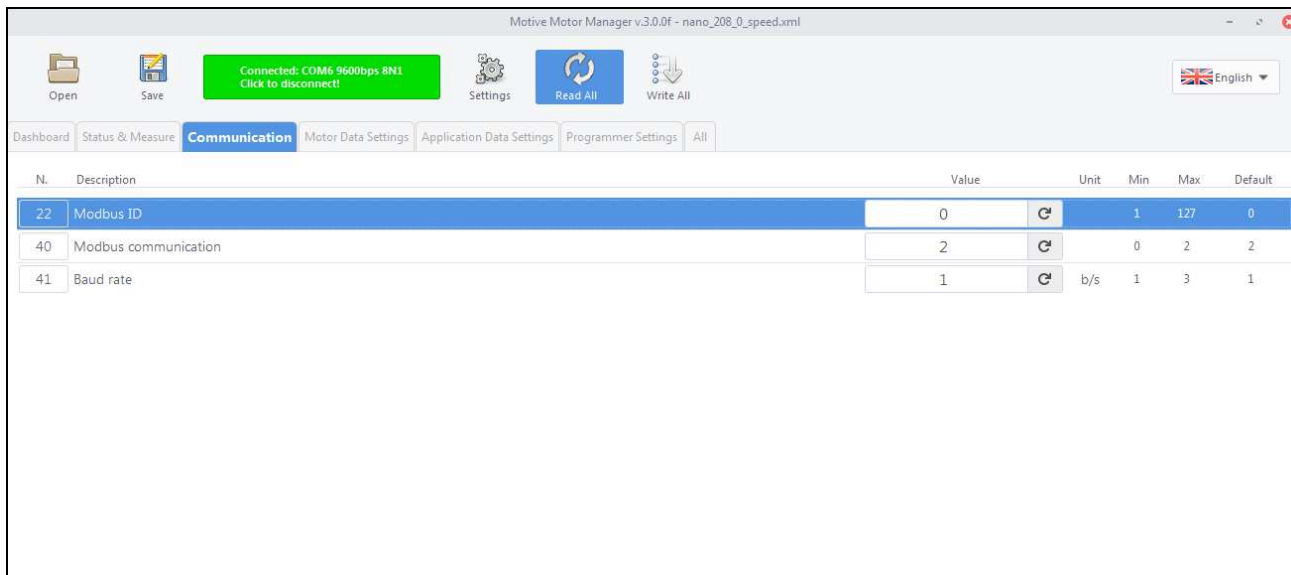

N.	Description	Value	Unit	Min	Max	Default
22	Modbus ID	0		1	127	0
40	Modbus communication	2		0	2	2
41	Baud rate	1	b/s	1	3	1

- **Motor Data Settings**, where you can insert the data from the data plate and set the motor performances;

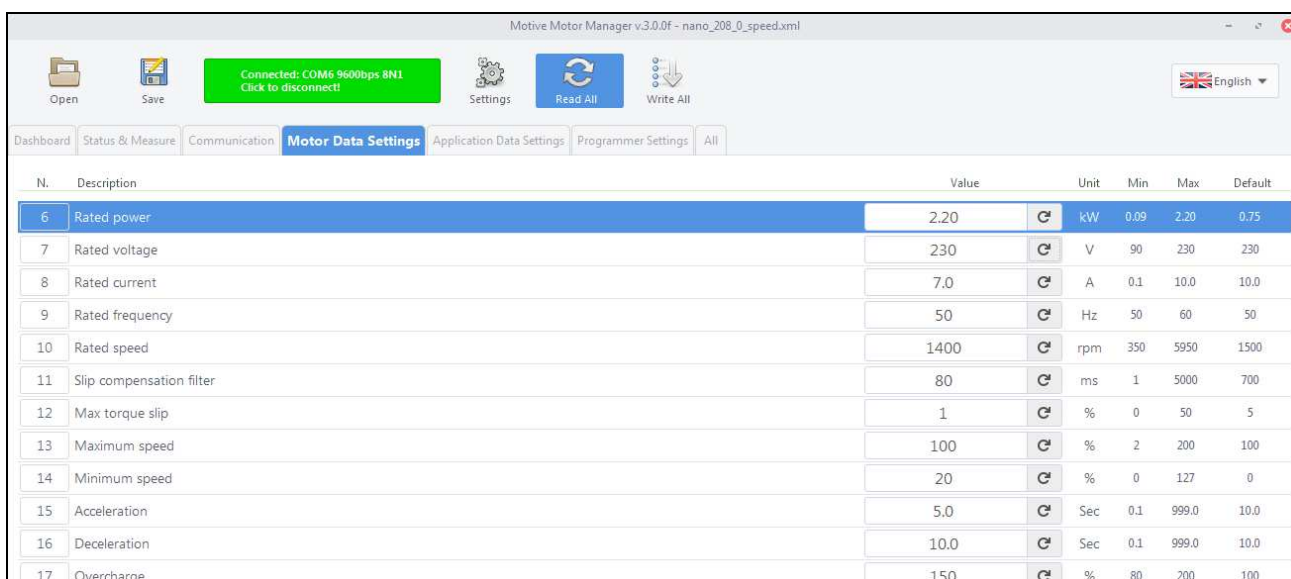

N.	Description	Value	Unit	Min	Max	Default
6	Rated power	2.20	kW	0.09	2.20	0.75
7	Rated voltage	230	V	90	230	230
8	Rated current	7.0	A	0.1	10.0	10.0
9	Rated frequency	50	Hz	50	60	50
10	Rated speed	1400	rpm	350	5950	1500
11	Slip compensation filter	80	ms	1	5000	700
12	Max torque slip	1	%	0	50	5
13	Maximum speed	100	%	2	200	100
14	Minimum speed	20	%	0	127	0
15	Acceleration	5.0	Sec	0.1	999.0	10.0
16	Deceleration	10.0	Sec	0.1	999.0	10.0
17	Overcharge	150	%	80	200	100

- **Application Data Settings**, where it is possible to configure the control mode, the I/ O module and other functions;

Motive Motor Manager v3.0.0f - nano_208_0_speed.xml

Open Save **Connected: COM6 9600bps 8N1** Click to disconnect! Settings Read All Write All English

Dashboard Status & Measure Communication Motor Data Settings **Application Data Settings** Programmer Settings All

N.	Description	Value	Unit	Min	Max	Default
5	Power line voltage	5	V	0	1	1
23	Restart enable	<input type="checkbox"/>		0	1	0
24	Dead time after alarm	10	Sec	1	999	5
29	Mode	0		0	4	0
56	Reset to factory data	0		0	541	0
26	Input signal	0		0	1	0
27	Analogue input 0 setup	1024		0	1	0
28	Analogue input 1 setup	0		0	1	0
50	Analogue input 0 function setup	0		0	3	1
51	Analogue input 1 function setup	0		0	3	1
53	Analogue output 0 function setup	0		0	2	1
43	Digital input 0 setup	299		0	4	1

- **All**, where you can find the complete list of parameters in numerical order.

Motive Motor Manager v3.0.0f - nano_208_0_speed.xml

Open Save **Connected: COM6 9600bps 8N1** Click to disconnect! Settings Read All Write All English

Dashboard Status & Measure Communication Motor Data Settings Application Data Settings Programmer Settings **All**



N.	Description	Value	Unit	Min	Max	Default
0	Inverter power	0.30	kW	0.75	2.20	0.75
1	Software version	408		0	0	0
5	Power line voltage	5		0	1	1
6	Rated power	2.20	kW	0.09	2.20	0.75
7	Rated voltage	230	V	90	230	230
8	Rated current	7.0	A	0.1	10.0	10.0
9	Rated frequency	50	Hz	50	60	50
10	Rated speed	1400	rpm	350	5950	1500
11	Slip compensation filter	80	ms	1	5000	700
12	Max torque slip	1	%	0	50	5
13	Maximum speed	100	%	2	200	100
14	Minimum speed	20	%	0	127	0

7d. Reading and writing parameters

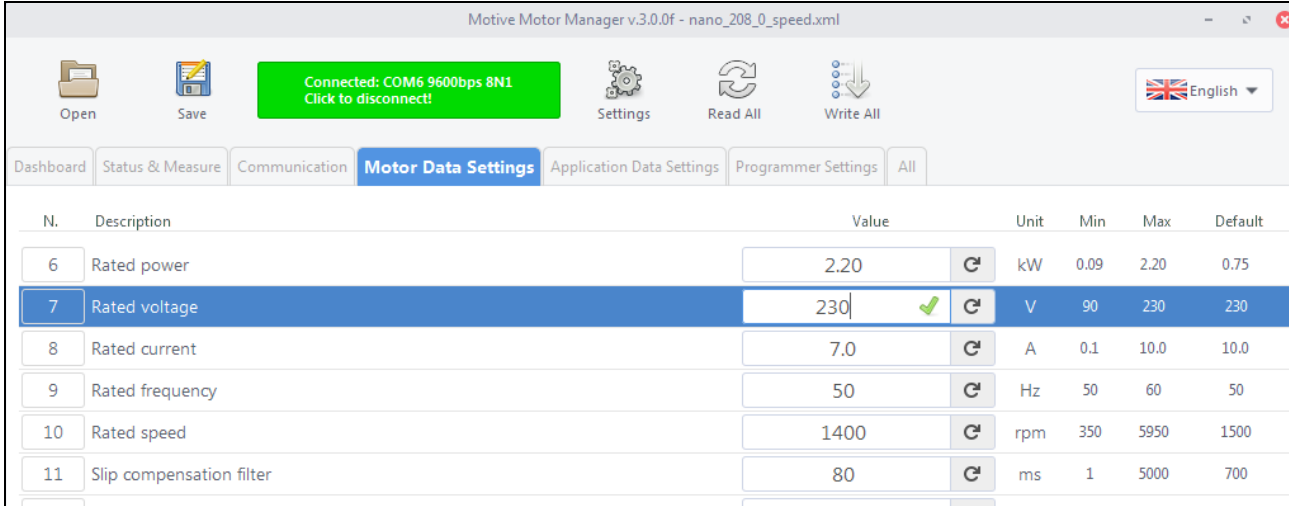
To change or write a new parameter value, write to the data bar and click  .



N.	Description	Value	Unit	Min	Max	Default
6	Rated power	2.20	kW	0.09	2.20	0.75
7	Rated voltage	230 	V	90	230	230
8	Rated current	7.0	A	0.1	10.0	10.0
9	Rated frequency	50	Hz	50	60	50
10	Rated speed	1400	rpm	350	5950	1500
11	Slip compensation filter	80	ms	1	5000	700

If the value written is correct (it means that the value is between the minimum and maximum limits set), the data bar will turn green for a short moment  ; if not, it will turn red  .



With the icons **Read All** and **Write All** all parameters can be read and written at once.



With the icon **Save** you can save a copy of the parameter list customized by the user, which can be uploaded later using



the icon **Open** .



NANO Modbus Parameters

NOTE: Not all the variables can be adjustable. In the column "Type" the letter R means "read only" and R/W means "Read and Write"

N°	Type	Variable definition	u.o.m	Min limit	Max limit	Default Speed	Default Vent	Default Comp	Default Oleo	Note
0	R	Inverter rated power	KW*100	75	220					
1	R	Inverter SW version	n	0	65535					
2	R/W	EMPTY	-	0	0	0	0	0	0	
3	R/W	EMPTY	-	0	0	0	0	0	0	
4	R/W	EMPTY	-	0	0	0	0	0	0	
5	R/W	Inverter power line voltage	-	0	1	1	1	1	1	0=110Vac 1=230Vac
6	R/W	Motor rated power	KW*100	13	220	220	220	220	220	
7	R/W	Motor rated voltage	V	90	230	230	230	230	230	
8	R/W	Motor rated current	A*10	10	100	100	100	100	100	
9	R/W	Motor rated frequency	Hz	50	60	50	50	50	50	
10	R/W	Motor rated speed	rpm	350	5950	1500	2891	2891	2891	
11	R/W	Slip compensation filter	ms	1	5000	700	700	700	700	
12	R/W	Maximum torque slip	%	0	50	5	5	5	5	
13	R/W	Maximum speed	%	2	200	100	100	120	100	
14	R/W	Minimum speed	%	0	127	0	0	60	10	
15	R/W	Acceleration	s*10	1	999	100	150	200	50	
16	R/W	Deceleration	s*10	1	999	100	150	200	5	
17	R/W	Overcharge	%In	80	200	100	100	100	100	Maximum current (% of rated current)
18	R/W	Rotation sense	-	0	1	0	0	0	0	
19	R/W	Speed/Pressure reference	Speed: rpm Vent: Psi*1000 Comp: Bar*100 Oleo: Bar*10	0	32767	200	200	200	200	
20	R/W	EMPTY	-	0	0	0	0	0	0	
21	R/W	Boost voltage	V	0	50	0	0	0	0	Additional voltage value to increase the torque value when the motors at very low speeds
22	R/W	Modbus ID	-	1	127	1	1	1	1	
23	R/W	Restart enable	-	0	1	1	1	1	1	0=OFF, 1=ON
24	R/W	Dead time after alarm	s	1	999	5	5	5	5	
25	R/W	EMPTY	-	0	0	0	0	0	0	
26	R/W	Input signal	-	0	1	0	0	0	0	0=Internal reference 1=Analog input
27	R/W	Analog Input 0 setup	-	0	1	0	0	0	0	0= 0...10V 1= 4...20mA
28	R/W	Analog Input 1 setup	-	0	1	0	1	1	1	0= 0...10V 1= 4...20mA
29	R/W	Mode	-	0	4	0	2	3	4	0=Open loop speed 1=Not used 2=Ventilation 3=Air compressor 4=Oleodynamic pump
30	R/W	Proportional factor		0	16383	12000	8000	12000	12000	
31	R/W	Integral factor		0	16383	500	25	500	250	
32	R/W	EMPTY	-	0	0	0	0	0	0	
33	R/W	Braking voltage	V	0	200	20	20	20	20	Function is OFF when value is 0
34	R/W	Braking time	ms	1	65535	2000	2000	2000	2000	Braking time controller
35	R/W	Minimum analog input setting (4-20mA signal)	mA*10	10	120	40	40	40	40	Minimum signal value in mA
36	R/W	Maximum analog input setting (4-20mA signal)	mA*10	50	300	200	200	200	200	Maximum signal value in mA
37	R/W	Minimum analog input setting (0-10V signal)	Volt*10	0	90	0	0	0	0	Minimum signal value in Volts
38	R/W	Fluxing current	%	70	120	100	100	100	100	



39	R/W	Maximum analog input setting (0-10V signal)	Volt*10	10	100	100	100	100	100	Maximum signal value in Volts
40	R/W	Modbus communication	-	0	2	0	0	0	0	0=OFF=Control only from the I/O Module 1=ON+KEY= Control from the I/O Module, reference value from modbus 2=ON=Program and control only from modbus
41	R/W	Baud rate	bit/s	0	3	1	1	1	1	0=4800 bit/s 1=9600 bit/s 2=14400 bit/s 3=19200 bit/s
42	R/W	EMPTY	-	0	0	0	0	0	0	
43	R/W	Digital input 0 setup	-	0	5	1	1	1	1	0=No function 1=Start/Stop motor command clockwise direction (1=Start, 0=Stop) 2=Start/Brake motor command (1=Start, 0=Brake) 3=Reverse motor command (it works only when Start/Stop motor command is set to a Digital Input with value=1) 4=Brake motor command (can also be used as an inverter enable or as an emergency stop) 5=Start/Stop motor command counter-clockwise direction (1=Start, 0=Stop)
44	R/W	Digital input 1 setup	-	0	5	0	0	0	0	0=No function 1=Start/Stop motor command clockwise direction (1=Start, 0=Stop) 2=Start/Brake motor command (1=Start, 0=Brake) 3=Reverse motor command (it works only when Start/Stop motor command is set to a Digital Input with value=1) 4=Brake motor command (can also be used as an inverter enable or as an emergency stop) 5=Start/Stop motor command counter-clockwise direction (1=Start, 0=Stop)
45	R/W	Digital input 2 setup	-	0	5	0	0	0	0	0=No function 1=Start/Stop motor command clockwise direction (1=Start, 0=Stop) 2=Start/Brake motor command (1=Start, 0=Brake) 3=Reverse motor command (it works only when Start/Stop motor command is set to a Digital Input with value=1) 4=Brake motor command (can also be used as an inverter enable or as an emergency stop) 5=Start/Stop motor command counter-clockwise direction (1=Start, 0=Stop)
46	R/W	EMPTY	-	0	0	0	0	0	0	
47	R/W	Digital output 0 setup	-	0	6	0	0	6	0	0=No function 1=Motor run 2=Motor rotation sense 3=Max speed reached 4=Fault 5=Motor stop 6=Compressor valve status
48	R/W	Digital output 1 setup	-	0	6	0	0	0	0	0=No function 1=Motor run 2=Motor rotation sense 3=Max speed reached 4=Fault 5=Motor stop 6=Compressor valve status
49	R/W	EMPTY	-	0	0	0	0	0	0	
50	R/W	Analog input 0 setup	-	0	4	0	0	0	0	0=No function 1=Speed reference with potentiometer 2=Speed reference with external signal 3=Current limit 4=PID feedback
51	R/W	Analog input 1 setup	-	0	4	0	4	4	4	0=No function 1=Speed reference with potentiometer 2=Speed reference with external signal 3=Current limit 4=PID feedback
52	R/W	EMPTY	-	0	0	0	0	0	0	
53	R/W	Analog output 0 setup	-	0	2	0	0	0	0	0=No function 1=0-12V motor speed reference (from 0% to the maximum speed value set) 2=0-12V motor current absorbed reference (from 0% to the maximum absorption set)
54	R/W	EMPTY	-	0	0	0	0	0	0	
55	R/W	Save parameters	-	0	65535	0	0	0	0	To save parameters write 1, then 541 (for acknowledgment the value returns to zero)
56	R/W	Reset factory data	-	0	65535	0	0	0	0	Reset to factory data writing: 1=Open loop speed 2=Ventilation 3=Air Compressor 4=Oleodynamic Pump After that write 541 (reset done when value becomes 0). To load default data, switch off and then switch on the inverter



57	R/W	EMPTY	-	0	0	0	0	0	0	
58	R/W	EMPTY	-	0	0	0	0	0	0	
59	R/W	EMPTY	-	0	0	0	0	0	0	
60	R/W	EMPTY	-	0	0	0	0	0	0	
61	R/W	EMPTY	-	0	0	0	0	0	0	
62	R/W	Stop time at pressure reached	s	5	300	-	5	15	5	It's the delay time when the motor stops when, at pressure reached, turns in no load mode
63	R/W	Pressure hysteresis	Vent: Psi*1000 Comp: Bar*100 Oleo: Bar*10	1	16000	-	50	20	10	Hysteresis expressed in bit ADC
64	R/W	Pressure range	Vent: Psi*1000 Comp: Bar*100 Oleo: Bar*10	0	16000	-	2000	16000	3000	Pressure rating sensor
65	R/W	Stop power with no load	%	0	100	50	20	50	0	% of minimum motor power below which it is stopped
66	R/W	Maximum pressure limitation	Vent: Psi*1000 Comp: Bar*100 Oleo: Bar*10	0	16000	-	2000	16000	800	Maximum pressure limit allowed inside the circuit
67	R/W	EMPTY	-	0	0	0	0	0	0	
68	R/W	EMPTY	-	0	0	0	0	0	0	
69	R/W	EMPTY	-	0	0	0	0	0	0	
70	R/W	EMPTY	-	0	0	0	0	0	0	
71	R/W	EMPTY	-	0	0	0	0	0	0	
72	R/W	EMPTY	-	0	0	0	0	0	0	
73	R/W	EMPTY	-	0	0	0	0	0	0	
74	R/W	EMPTY	-	0	0	0	0	0	0	
75	R/W	EMPTY	-	0	0	0	0	0	0	
76	R/W	EMPTY	-	0	0	0	0	0	0	
77	R/W	EMPTY	-	0	0	0	0	0	0	
78	R	Pressure reference	Vent: Psi*1000 Comp: Bar*100 Oleo: Bar*10	0	65535	-	0	0	0	average value measured in about 0.5s
79	R	Momentary value Bar	Vent: Psi*1000 Comp: Bar*100 Oleo: Bar*10	0	65535	-	0	0	0	average value measured in about 0.5s
80	R	Momentary value rpm	rpm	0	65535	0	0	0	0	average value measured in about 0.5s
81	R	Power	W	0	65535	0	0	0	0	average value measured in about 0.5s
82	R	RMS Current	A*10	0	65535	0	0	0	0	average value measured in about 0.5s
83	R	RMS Voltage	V	0	65535	0	0	0	0	average value measured in about 0.5s
84	R	IGBT Temperature	°C	0	65535	0	0	0	0	average value measured in about 0.5s
85	R	DcBus Voltage	V	0	65535	0	0	0	0	average value measured in about 0.5s
86	R	Turn direction	-	0	2	0	0	0	0	Actual turn direction: 0=Off 1=Clockwise direction 2=Counter clockwise direction
87	R	Frequency	Hz*10	0	65535	0	0	0	0	average value measured in about 0.5s
88	R	Motor status	-	0	1	0	0	0	0	average value measured in about 0.5s 0=Motor OFF 1=Motor ON
89	R	Last alarm recorded	-	0	65535	0	0	0	0	average value measured in about 0.5s
90	R	Alarm status	-	0	1	0	0	0	0	average value measured in about 0.5s
91	R	Fan status	-	0	1	0	0	0	0	average value measured in about 0.5s
92	R	Digital input status	bit	0	65535	0	0	0	0	average value measured in about 0.5s Bit 0 --> Status ON/OFF digital input 0 Bit 1 --> Status ON/OFF digital input 1 Bit 2 --> Status ON/OFF digital input 2
93	R	Digital output status	bit	0	65535	0	0	0	0	average value measured in about 0.5s Bit 0 --> Status ON/OFF digital output 0 Bit 1 --> Status ON/OFF digital output 1



94	R	Analog input 0 value	-	0	4096	0	0	0	0	average value measured in about 0.5s
95	R	Analog input 1 value	-	0	4096	0	0	0	0	average value measured in about 0.5s
96	R	Analog output 0 value	-	0	4096	0	0	0	0	average value measured in about 0.5s
97	R	PID reference input	UI	-32767	32767	0	0	0	0	PID regulator input reference
98	R	PID feedback input	UI	-32767	32767	0	0	0	0	PID regulator input measure
99	R	PID error input	UI	-32767	32767	0	0	0	0	PID regulator input error
100	R	EMPTY	-	0	0	0	0	0	0	
101	R	First SW version number	n	0	65535	-	-	-	-	First number of software version
102	R	Second SW version number	n	0	65535	-	-	-	-	Second number of software version
103	R	Third SW version number	n	0	65535	-	-	-	-	Third number of software version
104	R	EMPTY	-	0	0	0	0	0	0	
105	R/W	Modbus command rotation	-	0	2	0	0	0	0	0=Off 1=Clockwise rotation 2=Counter clockwise rotation
106	R/W	Modbus command speed/pressure	Speed: rpm Vent: Psi*1000 Comp: Bar*100 Oleo: Bar*10	0	32767	0	0	0	0	
107	R/W	I/O Module enable	-	0	1	1	1	1	1	0=Disabled 1=Enabled
108	R/W	EMPTY	-	0	0	0	0	0	0	
109	R/W	Modbus command acceleration	s*10	1	999	100	150	200	50	
110	R/W	Modbus command deceleration	s*10	1	999	100	150	200	5	
111	R/W	Enable new modbus command	-	0	1	0	0	0	0	With the value 1 the variable from 105 to 110 are enabled (R/W)
112	R/W	Debug_1	-	0	65535	0	0	0	0	
113	R/W	Debug_2	-	0	65535	0	0	0	0	
114	R/W	Debug_3	-	0	65535	0	0	0	0	
115	R/W	Debug_4	-	0	65535	0	0	0	0	
116	R/W	Debug_5	-	0	65535	0	0	0	0	
117	R/W	Debug_6	-	0	65535	0	0	0	0	
118	R/W	Debug_7	-	0	65535	0	0	0	0	
119	R/W	Debug_8	-	0	65535	0	0	0	0	
120	R/W	Debug_9	-	0	65535	0	0	0	0	

8. WARNINGS AND RISKS



These instructions must be read and strictly adhered to by who is doing the final installation and by the user, and they must also be made available to all the personnel that sees to the installation, calibration and maintenance of the device.

Qualification of personnel

The installation, commissioning and maintenance of the device must be carried out only by technically qualified personnel who is aware of the risks that the use of this device involves.

Dangers from non-compliance with safety regulations

Failure to comply with safety requirements, beyond endangering people and damaging the equipment, will void all warranty. The consequences of non-observance of safety requirements can be

- Activation failure of some system functions.
- Danger to people resulting from electrical and mechanical events.

Safety requirements for the user

All the accident prevention regulations must be implemented and complied with.
The keypad must be in a position from which the functioning of the system is visible.

Safety requirements for assembly and inspection

The customer must make sure that the assembly, inspection and maintenance operations are carried out by authorized and qualified personnel who has carefully read these instructions.

Work on the equipment and machinery must be performed on a non-operating machine.

Spare parts

The original parts and the accessories authorized by the manufacturer are an integral part of the safety of the equipment and of the machines. The use of components or accessories that are not original may compromise safety and will void the warranty.

LABELS have been affixed on the boards, on the microprocessors, that are used to trace the inverter model and the production serial number + production date code (Month/Year). Removing this label and/or deleting the writing on them will render the warranty of the inverter or keypad null and void.



It's strictly forbidden to wash the inverter with pressure washers or pressure pumps

Declaration of conformity

Motive srl based in Castenedolo (BS) – Italy

declares, under its exclusive responsibility,

that its range of “NANO” inverters and motor-inverters

is constructed in accordance with the following international regulations (latest edition):

- **EN60034-1**. Rotating electrical machines: rating and performance
- **EN60034-5**. Rotating machines: definition of degrees of protection
- **EN60034-30**. Rotating electrical machines: efficiency classes of single-speed, three-phase, cage-induction motors
- **EN60335-1**. Safety of household and similar electrical appliances
- **EN 55014-2**, Electromagnetic compatibility. Requirements for household appliances, electric tools and similar apparatus. Part 2: Immunity
- **EN 61000-3-2**, Limits for harmonic current emissions (equipment input current $\leq 16A$ per phase).
- **EN 61000-3-3**. Limitation of voltage fluctuations and flicker in low-voltage supply systems, for equipment with rated current $\leq 16A$
- **EN 61000-6-4**. Electromagnetic compatibility (EMC): Part 6-4: Generic standards – Emission standard for industrial environments
- **EN 50178**. Electronic equipment for use in power installations

as required by the Directives

- Low Voltage Directive (LVD) **2014/35/EEC**
- Electromagnetic Compatibility Directive (EMC) **2014/30/EEC**

EMC class B for DOMESTIC, COMMERCIAL AND LIGHT INDUSTRIAL ENVIRONMENT	With NANFILT or external EMC filter
EMC class B for INDUSTRIAL ENVIRONMENT	

- Ecodesign Directive for energy related products (ErP) **2019/1781/EEC**

The Legal Representative

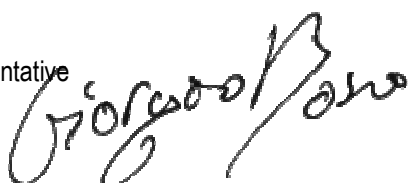

Declaration of conformity UKCA

Motive srl based in Castenedolo (BS) – Italy

declares, under its exclusive responsibility,

that its range of “NANO” inverters and motor-inverters

is constructed in accordance with the following international regulations (latest edition):

- **BS EN 60034-1**. Rotating electrical machines: rating and performance
- **BS EN IEC 60034-5**. Rotating machines: definition of degrees of protection
- **BS EN 60034-30**. Rotating electrical machines: efficiency classes of single-speed, three-phase, cage-induction motors
- **BS EN 60335-1**. Safety of household and similar electrical appliances
- **BS EN 55014-2**, Electromagnetic compatibility. Requirements for household appliances, electric tools and similar apparatus. Part 2: Immunity
- **BS EN 61000-3-2**, Limits for harmonic current emissions (equipment input current ≤ 16 A per phase).
- **BS EN 61000-3-3**. Limitation of voltage fluctuations and flicker in low-voltage supply systems, for equipment with rated current ≤ 16 A
- **BS EN 61000-6-4**. Electromagnetic compatibility (EMC): Part 6-4: Generic standards – Emission standard for industrial environments
- **BS EN 50178**. Electronic equipment for use in power installations

as required by the Directives

- Low Voltage Directive (LVD) **2014/35/EEC**
UK Electrical Equipment (Safety) **Regulations 2016**
- Electromagnetic Compatibility Directive (EMC) **2014/30/EEC**
UK EMC Electromagnetic Compatibility **Regulations 2016**

EMC class B for DOMESTIC, COMMERCIAL AND LIGHT INDUSTRIAL ENVIRONMENT	With NANFILT or external EMC filter
EMC class B for INDUSTRIAL ENVIRONMENT	

- Ecodesign Directive for energy related products (ErP) **2019/1781/EEC**
UK The Ecodesign for Energy-Related Products and Energy Information (Amendment) (EU Exit) **Regulations 2019**

The Legal Representative

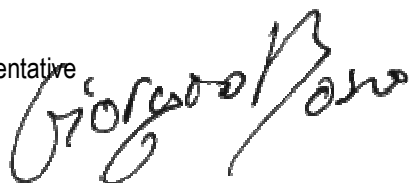

Declaration de conformite C_e



La société Motive S.r.l. sise à Castenedolo - BRESCIA (Italie)
déclare sous son entière responsabilité, que toute sa gamme des

variateurs de vitesse "**NANO**"

est réalisée conformément à la normative internationale

- **EN60034-1**. Rotating electrical machines: rating and performance
- **EN60034-5**. Rotating machines: definition of degrees of protection
- **EN60034-30**. Rotating electrical machines: efficiency classes of single-speed, three-phase, cage-induction motors
- **EN60335-1**. Safety of household and similar electrical appliances
- **EN 55014-2**, Electromagnetic compatibility. Requirements for household appliances, electric tools and similar apparatus.
Part 2: Immunity
- **EN 61000-3-2**, Limits for harmonic current emissions (equipment input current ≤ 16 A per phase).
- **EN 61000-3-3**. Limitation of voltage fluctuations and flicker in low-voltage supply systems, for equipment with rated current ≤ 16 A
- **EN 61000-6-4**. Electromagnetic compatibility (EMC): Part 6-4: Generic standards – Emission standard for industrial environments
- **EN 50178**. Electronic equipment for use in power installations

et elle est donc conforme aux arrêtés

LVD Arrêté No. 2573-14
EMC Arrêté No. 2574-14

Le représentant légal : Giorgio Bosio



motive

Motive s.r.l.
Via Le Ghiselle, 20
25014 CASTENEDOLO (BS) Italia
Tel.: +39.030.2677087
Fax.: +39.030.2677125
motive@e-motive.it
Capitale Sociale: Euro 50.000
Reg. Imprese: BS n°73020/2000-N, REA 422301
Cod. Fisc. e Part. IVA: 03580280174

Dot. GIORGIO BOSIO

ЕВРАЗИЙСКИЙ ЭКОНОМИЧЕСКИЙ СОЮЗ ДЕКЛАРАЦИЯ О СООТВЕТСТВИИ



Заявитель Общество с ограниченной ответственностью "ПРИВОД ГРАНД РЕДУКТОР"

Место нахождения и адрес места осуществления деятельности: Российская Федерация, Смоленская область, 214004, город Смоленск, улица Багратиона, дом 4, офис 46, основной государственный регистрационный номер: 1166733076608, номер телефона: +79203158381, адрес электронной почты: privodgrand@gmail.com

в лице Директора Шелеста Александра Иосифовича

заявляет, что Оборудование электротехническое промышленного назначения: Частотные преобразователи (инверторы), модели: NEO-WiFi, NEO-PUMP, NEO-SOLAR, NEO-OLEO, NEO-COMP, NEO-VENT, NANO

изготовитель «Motive Srl». Место нахождения и адрес места осуществления деятельности по изготовлению продукции: Via Le Ghiselle, 20, 25014 Castenedolo BS, Италия.

Продукция изготовлена в соответствии с Директивами 2014/30/EU "О электромагнитной совместимости", 2014/35/EU "По низковольтному оборудованию и системам".

Код ТН ВЭД ЕАЭС 8504409000. Серийный выпуск

соответствует требованиям

Технический регламент Таможенного союза «О безопасности низковольтного оборудования» (ТР ТС 004/2011), Технический регламент Таможенного союза «Электромагнитная совместимость технических средств» (ТР ТС 020/2011)

Декларация о соответствии принята на основании

Протокола испытаний № 32320.301120 от 30.11.2020 года, выданного Испытательной лабораторией «ОНИКС», аттестат аккредитации ОНПС RU.04ОПС0.ИЛ02.

Схема декларирования 1д

Дополнительная информация

ГОСТ 12.2.007.0-75 «Система стандартов безопасности труда. Изделия электротехнические. Общие требования безопасности»; ГОСТ 30804.6.2-2013 «Совместимость технических средств электромагнитная. Устойчивость к электромагнитным помехам технических средств, применяемых в промышленных зонах. Требования и методы испытаний», (раздел 8); ГОСТ 30804.6.4-2013 «Совместимость технических средств электромагнитная. Электромагнитные помехи от технических средств, применяемых в промышленных зонах. Нормы и методы испытаний», (раздел 7). Условия хранения продукции в соответствии с ГОСТ 15150-69 "Машины, приборы и другие технические изделия. Исполнения для различных климатических районов. Категории, условия эксплуатации, хранения и транспортирования в части воздействия климатических факторов внешней среды", срок хранения (службы, годности) указан в прилагаемой к продукции товаросопроводительной и/или эксплуатационной документации.

Декларация о соответствии действительна с даты регистрации по 06.12.2025 включительно

(подпись)



Шелест Александр Иосифович
(Ф.И.О. заявителя)

Регистрационный номер декларации о соответствии: ЕАЭС N RU Д-ИТ.НВ54.В.04614/20

Дата регистрации декларации о соответствии: 07.12.2020



Italia

CERTIFICATO

Nr. 50 100 1185 Rev.011

SI ATTESTA CHE / THIS IS TO CERTIFY THAT

IL SISTEMA DI GESTIONE PER LA QUALITÀ DI
THE QUALITY MANAGEMENT SYSTEM OF

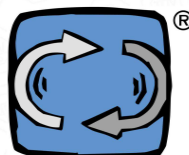

motive

MOTIVE S.r.l.

SEDE LEGALE E OPERATIVA:
REGISTERED OFFICE AND OPERATIONAL SITE:

**VIA LE GHISSELLE 20
IT - 25014 CASTENEDOLO (BS)**

È CONFORME AI REQUISITI DELLA NORMA
HAS BEEN FOUND TO COMPLY WITH THE REQUIREMENTS OF

UNI EN ISO 9001:2015

QUESTO CERTIFICATO È VALIDO PER IL SEGUENTE CAMPO DI APPLICAZIONE
THIS CERTIFICATE IS VALID FOR THE FOLLOWING SCOPE OF APPLICATION

**Progettazione e fabbricazione di motori elettrici, riduttori meccanici e
inverter (IAF 18, 19)**

***Design and manufacture of electrical motors, mechanical gearboxes
and variable speed drives (IAF 18, 19)***



SGQ N° 049A

Membro degli Accordi di Mutuo Riconoscimento
EA, IAF e ILAC
Signatory of EA, IAF and ILAC Mutual
Recognition Agreements

Per l'Organismo di Certificazione
For the Certification Body
TÜV Italia S.r.l.

Validità / Validity

Dal / From: **2022-03-03**

Al / To: **2025-03-02**

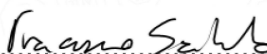

Francesco Scarlata
Direttore Divisione Business Assurance
Business Assurance Division Manager

Data emissione /
Issuing Date

2022-02-28

PRIMA CERTIFICAZIONE / FIRST CERTIFICATION: 2001-07-20

"LA VALIDITÀ DEL PRESENTE CERTIFICATO È SUBORDINATA A SORVEGLIANZA PERIODICA A 12 MESI E AL RIESAME COMPLETO DEL SISTEMA DI GESTIONE AZIENDALE CON PERIODICITÀ TRIENNALE"
"THE VALIDITY OF THE PRESENT CERTIFICATE DEPENDS ON THE ANNUAL SURVEILLANCE EVERY 12 MONTHS AND ON THE COMPLETE REVIEW OF COMPANY'S MANAGEMENT SYSTEM AFTER THREE-YEARS"

TÜV Italia • Gruppo TÜV SÜD • Via Carducci 125, Pal. 23 • 20099 Sesto San Giovanni (MI) • Italia • www.tuvsud.com/it

TÜV®

CERTIFICAT

CERTIFICADO

СЕРТИФИКАТ

認證證書

CERTIFICATE

ZERTIFIKAT

ALL THE DATA WAS COMPILED AND CHECKED WITH THE UTMOST CARE.
WE DO NOT HOWEVER ASSUME ANY RESPONSIBILITY FOR ANY ERRORS OR OMISSIONS.
MOTIVE srl MAY AT ITS SOLE DISCRETION CHANGE AT ANY TIME THE CHARACTERISTICS OF THE PRODUCTS SOLD.

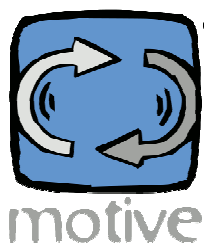

® Motive srl
www.motive.it
motive@motive.it
Tel: +39 030 2677087
Fax: +39 030 2677125

