

index

- Proving our motors quality,
- and comparing it to...
- New edition of delphi catalogues
- Still improving delphi casting parts...
- ..and Delphi ATDC brakes
- Motive buy.it. It works!
- Re-certification of our quality system
- Motive opens in India
- Enlarged plant in Italy
- Exhibitions 2007
- Prices

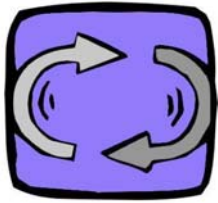

motive news



Notiziario

Number 0706

June 2007

www.motive.it

proving our motors quality,

In the last motive news edition, we declared our intention to “disclose the test reports of motive motors one-by-one, gradually uploading them on a page of www.motive.it. Nobody did it before, but rather than hiding, we've got only reasons to be proud and advertise them.”

Well, we did it. Just enter into our web site and log with the identity profile provided by motive, and you will find all the test reports.

Such results are conform to the data in the new catalogue revision (rev.03, that you can also find in the catalogues download area of www.motive.it)

When we say that our motors are as good as in our advertising, we prove it.

and comparing it to...

We tested in our laboratory all the brands that our distributors asked us to test, then we disassembled them piece by piece making photos of each part, and at the end we sent the test reports, the photos and the comparative charts to the most interested customers and, also, loaded them in our web.

The attention had been driven on such chosen brands basically by 2 main curiosities:

1. an explanation about the market low-price products disadvantages
2. how motive delphi series motors quality level was positioned in front of the most famous and expensive brands

The results can only have comforted all those companies that decided to be “motive-ated”. Little by little, we'll increase such interesting databank by adding new brands.

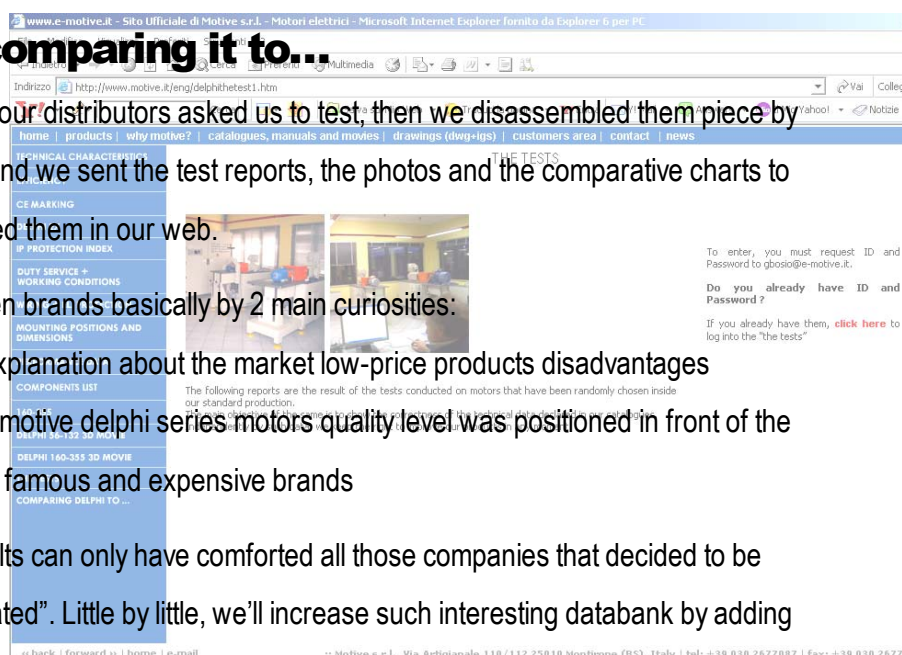

new edition of delphi catalogues

Delphi catalogue has been adjourned to follow the enlargement of our product range and all improvements.

The number of the catalogues that are available also in paper format has been increased, and the situation is now:

	Italian	English	French	Spanish	German
DELPHI	X	X	X	X	X
BOX	X	X	pdf	X	pdf
VARIO	X	X	pdf	pdf	pdf

Pdf= available only in pdf file

X= available also in paper



Among the novelties of the new delphi catalogue:

- B5 reduced flanges
- 63 power cooling
- the complete series of ATDC motors
- the new higher power of ATDC brakes
- the updated bearings list of cast-iron motors
- new motor types
- the delta Temperature of each motor,
- the adjourned performance data of each motor after the improvements of the last years and others...

still improving delphi casting parts...



Since Motive was born, in 2000, our housings moulds have been used and used (and more and more copied).

This is why it came the time to replace some of them, particularly from size 56 to size 80, and answer, with a further personalization, to those companies that doubt about the originality of our design. We'll do it by impressing our logo in them, but not making any changement that may create any marginal trouble to our distributors, onling providing advantages. Therefore the aesthetics, the overall dimensions and the connected parts interchangeability will not be affected.

Actual and new products can be put together on the same machine and in the same stock , the spare parts in stock can be used on the new housings like they are actually used

Bit by bit, the products made with such renewed parts will replace the actual ones in the next months, and the same adjournment may later be applied also on bigger sizes

...and delphi ATDC brakes

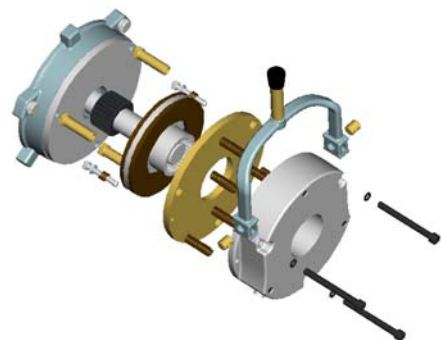

The brakes of ATDC motors are now more powerful, as you can see in the new edition of our catalogue and in this chart:

taglia	Static brakig torque in Nm	
	was	now is
ATDC 63	4,00	4,5
ATDC 71	5,00	8,0
ATDC 80	8,00	12,5
ATDC 90	15,00	25,0
ATDC 100	30,00	38,0
ATDC 112	40,00	70,0
ATDC 132	80,00	140,0
ATDC 160	150,00	210,0
ATDC 180	200,00	210,0
ATDC 200	300,00	420,0



In the next motive news edition, we'll probably announce a new set of brakes, with torque knob adjuster and 24Vdc power supply (particularly requested when inverters are used)

motive buy.it

It works!

It's now active. There, it is now possible, in real time, to:

- see whether the needed products are ready in stock for prompt delivery
- get any price confirmation of the chosen products
- send your order with a click

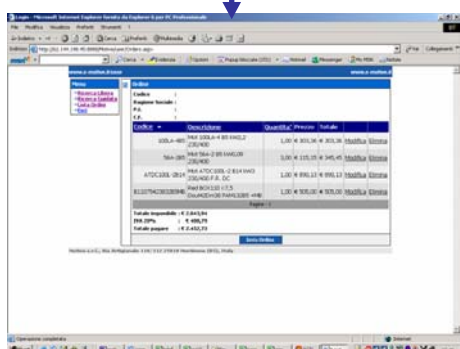
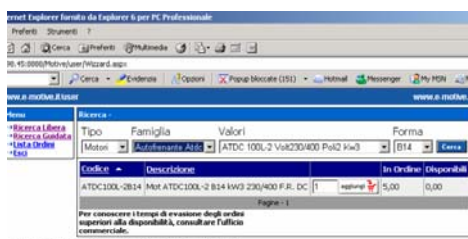

If you didn't yet received your login profile, and you'd like to use it, just ask us your own username and password.

re-certification of our quality system

6 years have passed since motive, first company in its field, got the ISO9001:2000 certification of its quality system

Each 3 years, the system must be re-certified. The last time has been in April.

The application field remains:

Design, manufacture management and service of electrical motors, mechanical reducers and accessories for power transmission (EA 19, 18)

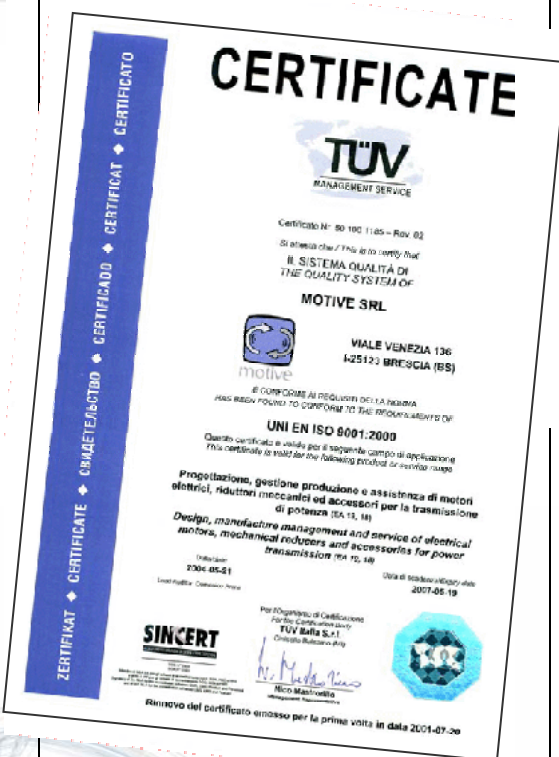

motive opens in India

India is the tenth most industrialized Country in the world, on the fulcrum of an ever increasing growth curve. With positive indicators such as a stable 8-9 per cent annual growth (been spurred by the manufacturing sector, which has now logged an 11.3 per cent rise), and a more than 35 per cent surge in exports, it is easy to understand why India is a leading destination for foreign investment.

Motive has always been innovative in its market approach, and India is not an opportunity to be lost.

So, in 2006 motive has signed a JV agreement with Rotomag (www.rotomag.com), Indian leader in the field of dc motors, to set up a new factory called "Rotomotive India", for the manufacturing in India of Motive products.

Its "big bang" growth strategy has already been felt in the whole Indian market.

We'll give you further informations and photos in the next edition of our motive news.



Enlarged plant in Italy

The factory in Montirone (BS) has also been influenced by new investments. In fact, in order to follow our strong growth rate, we had to increase our production and stocking capacity too, by incorporating a nearby building that covers further 1000 sqm



For sure, our customers already noted how our service was improved in the early 2006, when we moved to a bigger plant. This new investment is aimed on keeping, and possibly improving, such service level.

New CD-ROM

Our CD has been adjourned outside and inside.

It is including the new catalogues in 5 different languages, and together with delphi 56-132 and BOX 3D animations, we added a new animation about cast-iron motors 160-355

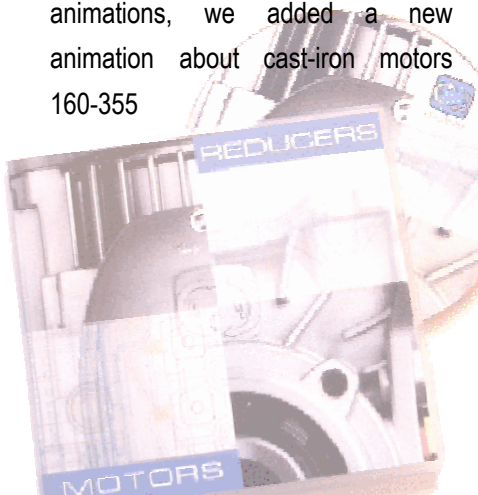

Exhibitions 2007

We've just been at:

- Enermotive (Milan, 6-10feb07)
- Motion, Drive and Automation (Hannover, 16-20apr07)



...and our participation has got its echo in many international magazines



Prices

This is that kind of title that attracts always a lot of attention...

Several customers have recently asked us what's our intention for next weeks about prices, considering that all steel products, and more and more manufacturers of motors and reducers, have recently increased (or announced it) their prices because of several facts that are globally influencing the costs. Well, don't worry, Motive knows the value of stability for its customers, and intends to not to increase its prices until the end of this year (if there will not be further unexpected and relevant events).

This is a value that we always wanted to add to our offer: the possibility of planning the business. A fluctuant price is not what our customers need.

Nevertheless, we cannot think that we can control any external happening, but what we can say is that:

1. we are very good in controlling our internal costs and our competitiveness
2. we always hold on as long as we can, waiting for the end of the year if possible, before any price correction
3. we'll always give priority to the preservation of our product quality and service level, distinguishing us by any mean, rather than falling into a price fight that could have bad consequences, at the end, on our customers satisfaction



motive
power transmission

Motive s.r.l.
Via Artigianale, 110/112
25010 Montirone (BS)
T +39 030 2677087
F +39 030 2677125
motive@e-motive.it
www.motive.it

Vertical line on the left side of the page.

Vertical line on the right side of the page.